

# *Automotive Tools*

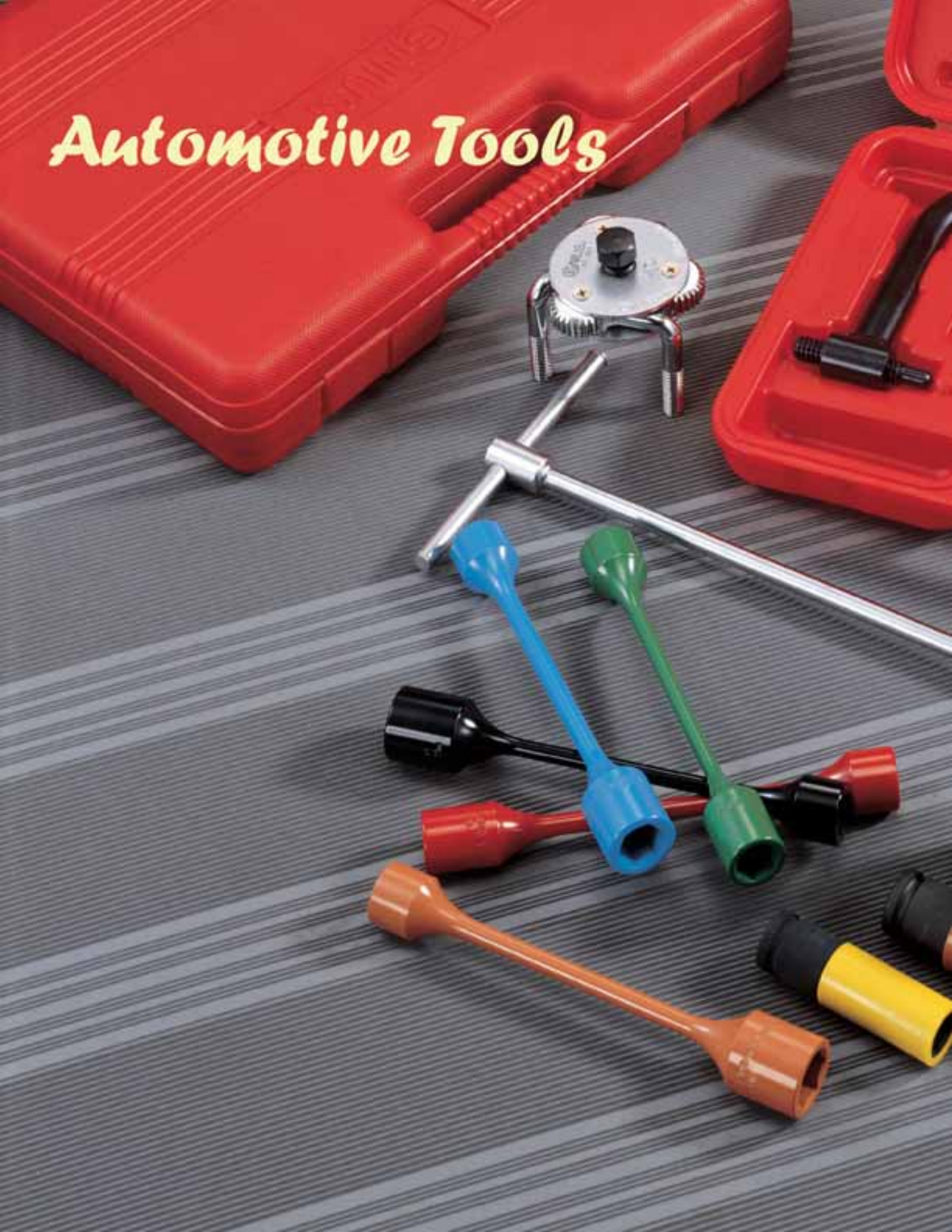



# Automotive Tools

## AT-4808 Inner Tie Rod Tool Set

Item No.	Description	Code
048014	14mm Open Jaw Driver	000800
048017	17mm Open Jaw Driver	000800
048033	33.6mm Open Jaw Driver	000800
048038	1-3/16" Open Jaw Driver	000800
048040	1-1/4" Open Jaw Driver	000800
048042	1-5/16" Open Jaw Driver	000800
048046	1-7/16" Open Jaw Driver	000800
048080	Long Socket	005500

Plastic Case

 2400 g      CODE : 008000

 6 Sets / 15.5 Kgs / 1.35 CUFT

AT-4808



These tools are specially designed for the inner tie rods that are inaccessible to adjust. The long socket can be easily used with seven open-jaw drivers, size 1-3/16", 1-1/4", 1-5/16", 1-7/16", 14mm, 17mm and 33.6mm, to most application. The inner tie rod can be easily removed and installed by slipping the long socket over the tie rod end and connecting it to the open-jaw driver.

## AT-09 Valve Spring Compressor

Item No.	Description	Code
009009	250mm(10") "C" Clamp	003200
009016	16mm Driving Adapter	000500
009019	19mm Driving Adapter	000500
009023	23mm Driving Adapter	000550
009025	25mm Driving Adapter	000550
009030	30mm Driving Adapter	000600
009070	70mm Length Pressure Screw	000400
009110	110mm Length Pressure Screw	000800

Plastic Case

 2000 g      CODE : 005900

 4 Sets / 9 Kgs / 1.0 CUFT

AT-09



These tools are designed to compress and release valve springs. After removal of collects, pantograph-type levers ensure a consistent coaxial contact with the valve. They work efficiently on all automobiles, trucks and tractor motors.

## AT-08 Disc Brake Caliper Tool Set

Item No.	Description	Code
<b>Rear Disc Brake Caliper Tool Adapter:</b>		
008AT4	32mm(1-1/4") Adapter	001100
008AT6	42mm(1-5/8") Adapter - Long Pins	001200
008AT7	42mm(1-5/8") Adapter - Short Pins	001200
008AT2	2"(51mm) Adapter	001200
008AT8	1-7/8"(43mm) Adapter	001300
008ATP	2-1/8"(54mm) Adapter	001300
008ATO	2-1/2"(63mm) Adapter	001400

<b>Front Disc Brake Caliper Tool Adapter:</b>		
008ATF	55mm(2-3/16") Adapter	001200

**Accessory:**

008ATA	3/8" Square Dr. Adapter	001100
008ATS	Pusher Screw Assembly	002400

Plastic Case

 2100 g      CODE : 012990

 10 Sets / 22 Kgs / 2.2 CUFT

AT-08



- Jack up the car and support on axle stands, Then remove the relevant road wheel
- Remove the caliper from its carrier and take out the brake pads
- Fit the main body of the wind back tool into the caliper, turn the main thrust bolt clockwise to compensate for the distance between the position and caliper body
- Select the correct adapter and fit it to the end of the main thrust bolt, continue rotating into the mating recesses in the piston
- Turn the thrust bolt to wild the caliper piston back into its housing
- Fit the new break pads and bolt the caliper back into the carrier

## AT-B01 Three-Legged Oil Filter Wrench

### Description

- Fits 3/8" Dr.
- Fully Adjustable from 2-1/2" ~ 4-5/16" (65mm ~ 110mm)

### Blow Case

 610 g      CODE : 001840

 36 Sets / 23 Kgs / 0.98 CUFT

- Design allows for broad range and tremendous gripping power.
- Gets into tight spots.
- Features heavy duty grooved legs for positive grip.
- Can be used directly with 3/8" Dr. ratchet handle

AT-B01



AT-EX6



## AT-EX6 6 Piece Screw Extractor Set

### Description

#### Screw Extractor:

- No. 1 1/8" ~ 1/4" (3 ~ 6mm)
- No. 2 1/4" ~ 5/16" (6 ~ 8mm)
- No. 3 5/16" ~ 7/16" (8 ~ 11mm)
- No. 4 7/16" ~ 9/16" (11 ~ 14mm)
- No. 5 9/16" ~ 3/4" (14 ~ 19mm)
- No. 6 3/4" ~ 1" (19 ~ 25mm)

#### Plastic Case

 250 g      CODE : 000860

 40 Sets / 11 Kgs / 0.71 CUFT

## SP-304A 4 Piece Spark Plug Socket Set

### Item No. Description

#### Spark Plug Socket:

- 326016 16mm(5/8") Spark Plug Socket
- 326021 20.6mm(13/16") Spark Plug Socket

#### Accessory:

- 320150 Extension Bar 150mmL
- 383363 Flexible Reversible Ratchet

#### Slide Card

 760 g      CODE : 004050



 20 Sets / 17 Kgs / 1.50 CUFT

SP-304A





A

## A Wheel Balancing Weight Tool

ITEM NO.	Size	Length mm	Weight g	PCS 	G.W. KGS	CUFT 	CODE @
560425	10"	250	370	60	23	1.83	002680

- Designed for fitting and removing wheel balancing weights
- Chrome Vanadium Steel
- Phosphatised finished



## B T-Handle Spark Plug Sockets

ITEM NO.	Size mm	Length mm	Weight g	PCS 	G.W. KGS	CUFT 	CODE @
4238016T	16	380	420	30	13.5	1.13	001600
4238021T	20.6	380	490	30	16.0	1.13	001600

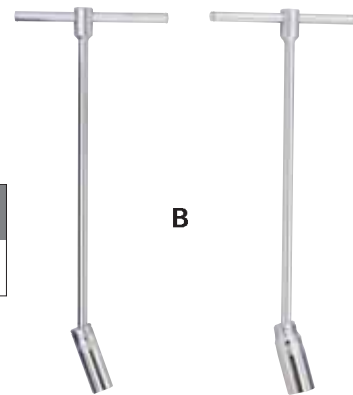
B



## C 3/8" & 1/2" Dr. Spark Plug Sockets

ITEM NO.	Drive Size	A Size	D1 mm	D2 mm	Length mm	Weight g	PCS 	G.W. KGS	CUFT 	CODE @
326016	3/8"	5/8"(16mm)	22	17.5	63	100	200	19.5	0.60	000505
326021	3/8"	13/16"(20.6mm)	28	17.5	63	120	120	19.0	0.52	000590
427016	1/2"	5/8"(16mm)	22	20.6	70	130	140	19.5	0.44	000565
427021	1/2"	13/16"(20.6mm)	28	20.6	70	150	120	19.0	0.52	000655

C



## Deep Spindle Nut Impact Socket Sets

### DI-407M 7 Piece Metric Deep Spindle Nut Impact Socket Set

Item No.	Description
1/2" Dr. Six-Point Deep Impact Socket:	
447830	30mm Deep Impact Socket
447832	32mm Deep Impact Socket
447833	33mm Deep Impact Socket
447834	34mm Deep Impact Socket
447835	35mm Deep Impact Socket
447836	36mm Deep Impact Socket
447838	38mm Deep Impact Socket
Plastic Tray	

 3750 g      CODE : 010070

 6 Sets / 24 Kgs / 0.94 CUFT

### DI-407S 7 Piece SAE Deep Spindle Nut Impact Socket Set

Item No.	Description
1/2" Dr. Six-Point Deep Impact Socket:	
467836	1-1/8" Deep Impact Socket
467838	1-3/16" Deep Impact Socket
467840	1-1/4" Deep Impact Socket
467842	1-5/16" Deep Impact Socket
467844	1-3/8" Deep Impact Socket
467846	1-7/16" Deep Impact Socket
467848	1-1/2" Deep Impact Socket
Plastic Tray	

 3750 g      CODE : 009700

 6 Sets / 24 Kgs / 0.94 CUFT

DI-407M  
(DI-407S)



TH-3416

## For Auto Repair Applications

### TH-3416 16 Piece 3/8" & 1/2" Dr. Bit Socket Set

Item No.	Description
3/8" Dr. Special Head Bit Socket:	
308 + 2336	6mm Hex Bit Socket 70mmL
308 + 2536	6mm Hex Bit Socket 105mmL
310 + 2547	7mm Hex Bit Socket 105mmL
310 + 2548	8mm Hex Bit Socket 105mmL
310 + 8508	M8 Triple Square Bit Socket 105mmL
340 + 8610	M10 Triple Square Bit Socket 140mmL
342 + 8612	M12 Triple Square Bit Socket 140mmL
1/2" Dr. Special Head Bit Socket:	
410 + 2785	5mm Hex Bit Socket 180mmL
410 + 2676	6mm Hex Bit Socket 160mmL
410 + 2896	6mm Hex Bit Socket 250mmL
410 + 2568	8mm Hex Bit Socket 120mmL
410 + 2898	8mm Hex Bit Socket 240mmL
440 + 2570	10mm Hex Bit Socket 140mmL
442 + 2172	12mm Hex Bit Socket 60mmL
447 + 2177	17mm Hex Bit Socket 60mmL
440 + 6555	T55 Star Bit Socket 105mmL
Blow Case	

 2400 g      CODE : 010460

 6 Sets / 15.5 Kgs / 1.21 CUFT



AT-0914

### AT-0914 Master Ball Joint Adapter Set

Item No.	Description	O.D.	I.D.	Length
097917	Plug	7/8"		
098354	Receiving tube	2-1/4"	2"	2"
098355	Installing tube	2"	1-3/4"	3"
099976	Receiving tube	2-1/2"	2-1/4"	1-1/2"
094508	Receiving cup	2-1/4"	1-7/8"	7/16"
092304	Receiving tube	2-1/2"	2-1/4"	3/4"
092305	Receiving tube	2-1/2"	2-1/4"	2-3/4"
092306	Receiving tube	3"	2-3/4"	2-1/4"
092307	Receiving tube	2-3/4"	2-7/16"	2-1/4"
093444	Receiving tube	2-7/8"	2-5/8"	2-7/8"
093967	Receiving tube	2-7/16"	2-3/16"	3-3/16"
093968	Remover/Installer	1-7/16"	3/4"	1"
093969	Installing tube	2"	1-3/4"	2-5/16"
093970	Receiving cup	2-1/8"	1-3/4"	1/2"

Blow Case

5660 g      CODE : 023700

3 Sets / 17 Kgs / 1.60 CUFT

- A complete ball joint adapter set
- Includes all the receive tubes and removing/installing adapters needed to work on most GM, Ford and Dodge two and four-wheel drive pickups,vans and sport utility Vehicles through 2002. Application chart included
- Works on press-fit upper and lower ball joints
- Set also includes a live center forcing screw plug

# Wheel Torque Tools

## Torque Sockets

ITEM NO.	Color	Square Dr. Inch	Wrench Size	Torque Limit	Length mm	Weight g	PCS	G.W. KGS	CUFT	CODE @
417M055	Green	1/2	17mm Hex	55 ft.lb. (75Nm)	206	250	50	13.5	0.80	002850
421M060	Black	1/2	21mm Hex	60 ft.lb. (81Nm)	206	300	50	16	0.80	002850
419M065	Yellow	1/2	19mm Hex(3/4")	65 ft.lb. (88Nm)	206	300	50	16	0.80	002850
417M080	Red	1/2	17mm Hex	80 ft.lb. (108Nm)	206	280	50	15	0.80	002850
419M080	Blue	1/2	19mm Hex(3/4")	80 ft.lb. (108Nm)	206	320	50	17	0.80	002850
421M080	Orange	1/2	21mm Hex	80 ft.lb. (108Nm)	206	320	50	17	0.80	002850
419M100	Grey	1/2	19mm Hex(3/4")	100 ft.lb. (135Nm)	206	340	50	18	0.80	002850
426S100	Brown	1/2	13/16" Hex	100 ft.lb. (135Nm)	206	350	50	18.5	0.80	002850
422M120D	White	1/2	22mm Hex	120 ft.lb. (163Nm)	220	420	50	22	0.80	003300
422M140D	Light Blue	1/2	22mm Hex	140 ft.lb. (190Nm)	220	440	50	23	0.80	003300
421M147D	Dark Grey	1/2	21mm Hex	147 ft.lb. (200Nm)	220	450	50	23.5	0.80	003300
430S140D	Light Green	1/2	15/16" Hex	140 ft.lb. (190Nm)	220	470	50	24.5	0.80	003300
434S140D	Light Brown	1/2	1-1/16" Hex	140 ft.lb. (190Nm)	220	490	50	25.5	0.80	003300
819M065	Yellow	1	19mm Hex(3/4")	65 ft.lb. (88Nm)	305	1250	12	16	0.70	011250
834S200	White	1	1-1/16" Hex(27mm)	200 ft.lb. (271Nm)	305	1360	12	17.5	0.70	011250
834S300	Light Blue	1	1-1/16" Hex(27mm)	300 ft.lb. (407Nm)	305	1470	12	18.5	0.70	011250
840S250	Brown	1	1-1/4" Hex(32mm)	250 ft.lb. (339Nm)	305	1490	12	19	0.70	011250
838S300	Yellow	1	1-3/16" Hex(30mm)	300 ft.lb. (407Nm)	305	1540	12	19.5	0.70	011250
838S400	Red	1	1-3/16" Hex(30mm)	400 ft.lb. (542Nm)	305	1660	12	21	0.70	011250
842S325	Dark Red	1	1-5/16" Hex	325 ft.lb. (441Nm)	305	1530	12	19.5	0.70	011250
842S475	Green	1	1-5/16" Hex	475 ft.lb. (644Nm)	305	1840	12	23	0.70	011250
848S475	Grey	1	1-1/2" Hex(38mm)	475 ft.lb. (644Nm)	305	1870	12	23.5	0.70	011250
848S525	Blue	1	1-1/2" Hex(38mm)	525 ft.lb. (712Nm)	305	1920	12	24	0.70	011250
841M400	Orange	1	41mm Hex(1-5/8")	400 ft.lb. (542Nm)	305	1720	12	21.5	0.70	011250
826S475	Black	1	13/16" Square	475 ft.lb. (644Nm)	305	1890	12	23.5	0.70	011250



TO-410M

### TO-410M 10 Piece 1/2" Dr. Metric Car Wheel Torque Socket Set

Item No.	Color	Wrench Size	Description
<b>1/2" Dr. Six-Point Metric Thin Wall Deep Impact Socket:</b>			
448517W	Yellow	17mm	17mm - With Yellow Plastic Sleeve
448519W	Red	19mm(3/4")	19mm(3/4") - With Red Plastic Sleeve
448521W	Orange	21mm	21mm - With Orange Plastic Sleeve
<b>1/2" Dr. Wheel Torque Socket:</b>			
417M055	Green	17mm Hex	55 ft.lb. (75Nm)
421M060	Black	21mm Hex	60 ft.lb. (81Nm)
419M065	Yellow	19mm Hex(3/4")	65 ft.lb. (88Nm)
417M080	Red	17mm Hex	80 ft.lb. (108Nm)
419M080	Blue	19mm Hex(3/4")	80 ft.lb. (108Nm)
421M080	Orange	21mm Hex	80 ft.lb. (108Nm)
419M100	Grey	19mm Hex(3/4")	100 ft.lb. (135Nm)

Blow Case

3750 g CODE : 021000  
4 Sets / 16 Kgs / 1.65 CUFT

### TO-412MS 12 Piece 1/2" Dr. Metric & SAE Car Wheel Torque Socket Set

Item No.	Color	Wrench Size	Description
<b>1/2" Dr. Six-Point Metric Thin Wall Deep Impact Socket:</b>			
448517W	Yellow	17mm	17mm - With Yellow Plastic Sleeve
448519W	Red	19mm(3/4")	19mm(3/4") - With Red Plastic Sleeve
448521W	Orange	21mm	21mm - With Orange Plastic Sleeve
<b>1/2" Dr. Six-Point SAE Thin Wall Deep Impact Socket:</b>			
468526W	Blue	13/16"	13/16" - With Blue Plastic Sleeve
<b>1/2" Dr. Metric Wheel Torque Socket:</b>			
417M055	Green	17mm Hex	55 ft.lb. (75Nm)
421M060	Black	21mm Hex	60 ft.lb. (81Nm)
419M065	Yellow	19mm Hex(3/4")	65 ft.lb. (88Nm)
417M080	Red	17mm Hex	80 ft.lb. (108Nm)
419M080	Blue	19mm Hex(3/4")	80 ft.lb. (108Nm)
421M080	Orange	21mm Hex	80 ft.lb. (108Nm)
419M100	Grey	19mm Hex(3/4")	100 ft.lb. (135Nm)
<b>1/2" Dr. SAE Wheel Torque Socket:</b>			
426S100	Brown	13/16" Hex	100 ft.lb. (135Nm)

Blow Case



TO-412MS

4375 g CODE : 024600  
4 Sets / 18.5 Kgs / 1.65 CUFT

# Wheel Torque Tools

## Torque Extensions

ITEM NO.	Color	Square Dr. Inch	Torque Limit	Length mm	Weight g	PCS	G.W. KGS	CUFT	CODE @
487065	Green	1/2	65 ft.lb.(90 Nm)	180	170	50	9.5	0.80	002400
487075	Black	1/2	75 ft.lb.(100 Nm)	180	170	50	9.5	0.80	002400
487080	Yellow	1/2	80 ft.lb.(110 Nm)	180	185	50	10.5	0.80	002400
487090	Red	1/2	90 ft.lb.(120 Nm)	180	190	50	10.5	0.80	002400
487100	Blue	1/2	100 ft.lb.(135 Nm)	180	200	50	11	0.80	002400
487110	Orange	1/2	110 ft.lb.(150 Nm)	180	215	50	12	0.80	002400
487120	Grey	1/2	120 ft.lb.(160 Nm)	180	225	50	12.5	0.80	002400
487130	Brown	1/2	130 ft.lb.(175 Nm)	180	240	50	13	0.80	002400
487140	White	1/2	140 ft.lb.(190 Nm)	180	245	50	13.5	0.80	002400
487150	Light Blue	1/2	150 ft.lb.(200 Nm)	180	265	50	14.5	0.80	002400
687175	Black	3/4	175 ft.lb.(240 Nm)	180	450	30	14.5	0.44	006800
687250	Black	3/4	250 ft.lb.(340 Nm)	180	470	30	15	0.44	006800
687350	Black	3/4	350 ft.lb.(475 Nm)	180	540	30	17	0.44	006800
687475	Black	3/4	475 ft.lb.(645 Nm)	180	650	30	20.5	0.44	006800
887250	Black	1	250 ft.lb.(340 Nm)	254	1030	16	17.5	0.48	009000
887350	Black	1	350 ft.lb.(475 Nm)	254	1140	16	19	0.48	009000
887475	Black	1	475 ft.lb.(645 Nm)	254	1310	16	22	0.48	009000
887650	Black	1	650 ft.lb.(880 Nm)	254	1520	16	25.5	0.48	009000



TO-410EXT

### TO-410EXT 10 Piece 1/2" Dr. Torque Extension Bar Set

Item No.	Color	Description
487065	Green	65 ft.lb.(90 Nm)
487075	Black	75 ft.lb.(100 Nm)
487080	Yellow	80 ft.lb.(110 Nm)
487090	Red	90 ft.lb.(120 Nm)
487100	Blue	100 ft.lb.(135 Nm)
487110	Orange	110 ft.lb.(150 Nm)
487120	Grey	120 ft.lb.(160 Nm)
487130	Brown	130 ft.lb.(175 Nm)
487140	White	140 ft.lb.(190 Nm)
487150	Light Blue	150 ft.lb.(200 Nm)

Blow Case

3250 g CODE : 021600

4 Sets / 14 Kgs / 1.07 CUFT

### TO-405EXT 5 Piece 1/2" Dr. Torque Extension Bar Set

Item No.	Color	Description
487065	Green	65 ft.lb.(90 Nm)
487080	Yellow	80 ft.lb.(110 Nm)
487100	Blue	100 ft.lb.(135 Nm)
487120	Grey	120 ft.lb.(160 Nm)
487140	White	140 ft.lb.(190 Nm)

Blow Case

1500 g CODE : 011400

8 Sets / 13 Kgs / 0.88 CUFT

TO-405EXT



### Torque Extension Bars:





- Torque Extensions are designed for 1/2" Dr. impact wrench rated 380-420 ft.lb.; 3/4" Dr. impact wrench rated 750 ft.lb.; 1" Dr. impact wrench rated 1,500 ft.lb.
- The various drive sizes and torque limits allow use of any impact socket with a torque extension to match the different lug nut sizes found on vehicles
- Helps prevent over-torquing of wheel nuts and can minimize wheel distortion.
- The unique design allows the length and diameter of the torque extension shaft to flex with each blow of the impact wrench once the specified torque is reached.
- Accurate to within 4%.

Made of Chrome Vanadium Steel



# Wheel Torque Tools

## 1/2" Dr. Thin Wall Deep Impact Sockets with Plastic Sleeves



ITEM NO.	Color	Description Size	Length mm	Weight g	PCS 	G.W. KGS	CUFT 	CODE @
448517W		17mm - With Yellow Plastic Sleeve	86	190	120	24.0	0.52	001030
448519W		19mm (3/4") - With Red Plastic Sleeve	86	200	120	25.0	0.52	001120
448521W		21mm - With Orange Plastic Sleeve	86	250	60	16.5	0.45	001160
468526W		13/16" - With Blue Plastic Sleeve	86	250	60	16.5	0.45	001160

### Features:

- Thin Wall Deep Impact Sockets are designed to allow easy access to recessed wheel nuts where space is limited.
- Changeable plastic sleeves.
- With additional outside plastic sleeve to protect the rims when screwing the wheel nuts/screws.
- Special design for American, European and Japanese cars.

### CW-403M 3 Piece Metric Car Wheel Thin Wall Deep Impact Socket Set

Item No.	Color	Description
1/2" Dr. Six-Point Metric Thin Wall Deep Impact Socket:		
448517W		17mm - With Yellow Plastic Sleeve
448519W		19mm (3/4") - With Red Plastic Sleeve
448521W		21mm - With Orange Plastic Sleeve



 800 g      CODE : 003310  
 20 Sets / 17 Kgs / 1.0 CUFT

CW-403M



### CW-404MS 4 Piece Metric & SAE Car Wheel Thin Wall Deep Impact Socket Set







Item No.	Color	Description
1/2" Dr. Six-Point Metric Thin Wall Deep Impact Socket:		
448517W		17mm - With Yellow Plastic Sleeve
448519W		19mm (3/4") - With Red Plastic Sleeve
448521W		21mm - With Orange Plastic Sleeve
1/2" Dr. Six-Point SAE Thin Wall Deep Impact Socket:		
468526W		13/16" - With Blue Plastic Sleeve



 1170 g      CODE : 004470  
 10 Sets / 13 Kgs / 0.93 CUFT

CW-404MS



### CW-406M 6 Piece Metric Car Wheel COLOUR MATCH® Set









Item No.	Color	Description
1/2" Dr. Six-Point Metric Thin Wall Deep Impact Socket:		
448517W		17mm - With Yellow Plastic Sleeve
448519W		19mm(3/4") - With Red Plastic Sleeve
448521W		21mm - With Orange Plastic Sleeve
1/2" Dr. Torque Extension Bar:		
487080		80 ft.lb.(110 Nm)
487090		90 ft.lb.(120 Nm)
487110		110 ft.lb.(150 Nm)



 1760 g      CODE : 009550  
 5 Sets / 10 Kgs / 0.93 CUFT

CW-406M



### CW-408MS 8 Piece Metric & SAE Car Wheel COLOUR MATCH® Set

Item No.	Color	Description
1/2" Dr. Six-Point Metric Thin Wall Deep Impact Socket:		
448517W		17mm - With Yellow Plastic Sleeve
448519W		19mm(3/4") - With Red Plastic Sleeve
448521W		21mm - With Orange Plastic Sleeve
1/2" Dr. Six-Point SAE Thin Wall Deep Impact Socket:		
468526W		13/16" - With Blue Plastic Sleeve
1/2" Dr. Torque Extension Bar:		
487080		80 ft.lb.(110 Nm)
487090		90 ft.lb.(120 Nm)
487100		100 ft.lb.(135 Nm)
487110		110 ft.lb.(150 Nm)

 2170 g      CODE : 013110  
 5 Sets / 12 Kgs / 0.93 CUFT

CW-408MS



### Torque Extension Bars:

- Torque Extensions are designed for 1/2" Dr. impact wrench rated 380-420 ft.lb.; 3/4" Dr. impact wrench rated 750 ft.lb.; 1" Dr. impact wrench rated 1,500 ft.lb.
- Helps prevent over-torquing of wheel nuts and can minimize wheel distortion.
- The unique design allows the length and diameter of the torque extension shaft to flex with each blow of the impact wrench once the specified torque is reached.
- Accurate to within 4%.

# Wheel Impact Sockets

## 1/2" Dr. Flip Sockets



ITEM NO.	Drive Square	Hex A	Hex B	Weight g	PCS	G.W. KGS	CUFT	CODE @
41651921	1/2"	19mm	21mm	220	120	27.5	0.52	000465
41601719	1/2"	17mm	19mm	160	120	20.5	0.52	000465
49652426	1/2"	3/4"	13/16"	220	120	27.5	0.52	000465
49602224	1/2"	11/16"	3/4"	160	120	20.5	0.52	000465



FD-410M

## FD-410M 1/2" Dr. 9 Piece Metric Wheel Impact Socket Set

Item No. Description

**1/2" Dr. Six-Point Impact Socket:**

413813	13mm Impact Socket
413814	14mm Impact Socket
413817	17mm Impact Socket
413819	19mm Impact Socket
413821	21mm Impact Socket
413824	24mm Impact Socket

**1/2" Dr. Six-Point Deep Impact Socket:**

417817	17mm Deep Impact Socket
417819	19mm Deep Impact Socket
417822	22mm Deep Impact Socket

Metal Box

1650 g CODE : 002825

10 Sets / 17.5 Kgs / 0.40 CUFT

## 3/4" Dr. Extra Long Impact Budd Wheel Sockets

ITEM NO.	A Size	B mm	C mm	D mm	Length mm	Weight g	PCS	G.W. KGS	CUFT	CODE @
649833	33 mm Hex	48	74	42	230	1550	10	16.5	0.41	008600
669834	1-1/16" Hex	42	74	42	230	1560	10	16.6	0.41	008600
669836	1-1/8" Hex	43	74	42	230	1560	10	16.6	0.41	008600
669840	1-1/4" Hex	47	74	42	230	1530	10	16.3	0.41	008600
669848	1-1/2" Hex	54	74	42	230	1750	10	18.5	0.41	008600
669826S	13/16" Square	43	74	42	230	1500	10	16.0	0.41	008600

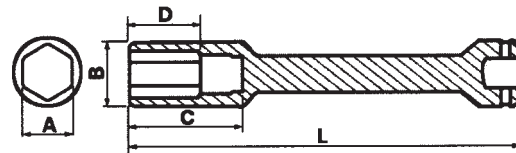



### Cr-Mo Extra Long Impact Sockets

Designed specifically for the truck industry. Extra long sockets are perfect for truck wheels and other hard to reach applications. Eliminating the need for extension bars reduces torque loss, as well as saving your time and money.

Made of Chrome Molybdenum Steel



# Truck Wheel Sockets

## 3/4" Dr. Metric Budd Wheel Sockets

ITEM NO.	A Square	D1 mm	D2 mm	Length mm	Weight g	PCS 	G.W. KGS	CUFT 	CODE @
649517S	17mm	34	40	90	610	30	19.5	0.52	001905
649519S	19mm	38	40	90	630	30	20.0	0.52	001905
649520S	20mm	40	40	90	625	30	20.0	0.52	001905
649521S	21mm	40	40	90	650	30	20.5	0.52	001905



## 3/4" Dr. SAE Budd Wheel Sockets

ITEM NO.	A Square	D1 mm	D2 mm	Length mm	Weight g	PCS 	G.W. KGS	CUFT 	CODE @
669522S	11/16"	34	40	90	610	30	19.5	0.52	001905
669524S	3/4"	38	40	90	630	30	20.0	0.52	001905
669526S	13/16"	40	40	90	650	30	20.5	0.52	001905

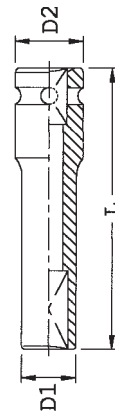

### CM-608M4 3/4" Dr. 8 Piece Metric Budd Wheel Socket Set

#### Item No. Description



#### 3/4" Dr. Budd Wheel Impact Socket:

- 649519S 19mm Square Deep Impact Socket
- 649521S 21mm Square Deep Impact Socket

#### 3/4" Dr. Six-Point Deep Impact Socket:

- 649527 27mm Deep Impact Socket
- 649530 30mm Deep Impact Socket
- 649532 32mm Deep Impact Socket
- 649535 35mm Deep Impact Socket
- 649538 38mm Deep Impact Socket
- 649541 41mm Deep Impact Socket

#### Metal Box

-  6500 g CODE : 018745
-  4 Sets / 27 Kgs / 0.62 CUFT

### CM-608S4 3/4" Dr. 8 Piece SAE Budd Wheel Socket Set

#### Item No. Description



#### 3/4" Dr. Budd Wheel Impact Socket:

- 669524S 3/4" Square Deep Impact Socket
- 669526S 13/16" Square Deep Impact Socket

#### 3/4" Dr. Six-Point Deep Impact Socket:

- 669534 1-1/16" Deep Impact Socket
- 669536 1-1/8" Deep Impact Socket
- 669538 1-3/16" Deep Impact Socket
- 669540 1-1/4" Deep Impact Socket
- 669544 1-3/8" Deep Impact Socket
- 669548 1-1/2" Deep Impact Socket

#### Metal Box

-  6300 g CODE : 018745
-  4 Sets / 27 Kgs / 0.62 CUFT

### TR-611MS 11 Piece 3/4" Dr. SAE & Metric Truck Wheel Impact Socket Set

#### Item No. Description

#### 3/4" Dr. Metric Square Impact Socket:

- 649517S 17mm Square Impact Socket
- 649521S 21mm Square Impact Socket

#### 3/4" Dr. SAE Square Impact Socket:

- 669526S 13/16" Square Impact Socket

#### Six-Point Metric Deep Impact Socket:

- 649533 33mm Deep Impact Socket
- 649535 35mm Deep Impact Socket
- 649538 38mm Deep Impact Socket
- 649541 41mm Deep Impact Socket

#### 3/4" Dr. SAE Deep Thin Wall Impact Socket:

- 669534T 1-1/16" Deep Thin Wall Impact Socket
- 669536T 1-1/8" Deep Thin Wall Impact Socket
- 669540T 1-1/4" Deep Thin Wall Impact Socket

#### 3/4" Dr. SAE Deep Budd Wheel Impact Socket:

- 669548B 1-1/2" Deep Budd Wheel Impact Socket

#### Blow Case

-  8540 g CODE : 023090
-  2 Sets / 18 Kgs / 0.95 CUFT



CW-608M4  
(CW-608S4)





TR-611MS





# Truck Wheel Sockets



## 1" Dr. Metric Budd Wheel Sockets

ITEM NO.	A Square	D1 mm	D2 mm	Length mm	Weight g	PCS 	G.W. KGS	CUFT 	CODE @
846017S	17mm	40	50	60	510	30	16.5	0.38	001680
846019S	19mm	42	50	60	530	30	17.0	0.38	001680
846021S	21mm	44	50	60	530	30	17.0	0.38	001680
847617S	17mm	37	50	76	650	30	20.5	0.52	002365
847619S	19mm	43	50	76	670	30	21.5	0.52	002365
847621S	21mm	47	50	76	670	30	21.5	0.52	002365
849517S	17mm	41	50	90	780	20	17.0	0.34	002470
849519S	19mm	43	50	90	850	20	18.0	0.34	002470
849520S	20mm	45	50	90	850	20	19.0	0.34	002470
849521S	21mm	46	50	90	990	20	21.0	0.34	002470
849522S	22mm	47	50	90	990	20	21.0	0.34	002470

## 1" Dr. SAE Budd Wheel Sockets

ITEM NO.	A Square	D1 mm	D2 mm	Length mm	Weight g	PCS 	G.W. KGS	CUFT 	CODE @
866024S	3/4"	42	50	60	530	30	17.0	0.38	001680
866026S	13/16"	44	50	60	530	30	17.0	0.38	001680
867624S	3/4"	43	50	76	670	30	21.5	0.52	002365
867626S	13/16"	47	50	76	670	30	21.5	0.52	002365
869522S	11/16"	41	50	90	780	20	17.0	0.34	002470
869524S	3/4"	43	50	90	850	20	18.0	0.34	002470
869526S	13/16"	45	50	90	990	20	21.0	0.34	002470

## 1" Dr. Dual Budd Wheel Sockets

ITEM NO.	A Hex	B Square	D1 mm	D2 mm	Length mm	Weight g	PCS 	G.W. KGS	CUFT 	CODE @
849035B	35mm	17mm	54	52	90	1170	10	13.0	0.31	003150
849038B	38mm	20mm	58	52	90	1280	10	14.0	0.31	003675
849041B	41mm	21mm	61	52	90	1440	10	15.5	0.31	004200
869048B	1-1/2"	13/16"	58	52	90	1280	10	14.0	0.31	003675

• Incorporating both Hex and Budd Sockets in one. Designed to be used on a trucks rear wheel.

### Dual Budd Wheel Sockets

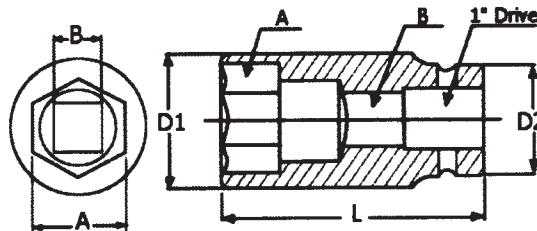

# Truck Wheel Sockets

## TR-811M 11 Piece 1" Dr. Metric Truck Wheel Impact Socket Set

Item No.	Description
<b>1" Dr. Square Impact Socket:</b>	
846017S	17mm Square Impact Socket
846020S	20mm Square Impact Socket
846021S	21mm Square Impact Socket
<b>1" Dr. Six-Point Impact Socket:</b>	
847027	27mm Impact Socket
847030	30mm Impact Socket
847032	32mm Impact Socket
<b>1" Dr. Six-Point Deep Impact Socket:</b>	
849533	33mm Deep Impact Socket
849535	35mm Deep Impact Socket
849536	36mm Deep Impact Socket
849538	38mm Deep Impact Socket
849541	41mm Deep Impact Socket

Blow Case

9340 g CODE : 023400

2 Sets / 20 Kgs / 0.95 CUFT

## TR-811MS 11 Piece 1" Dr. SAE & Metric Truck Wheel Impact Socket Set

Item No.	Description
<b>1" Dr. Metric Square Impact Socket:</b>	
846017S	17mm Square Impact Socket
846021S	21mm Square Impact Socket
<b>1" Dr. SAE Square Impact Socket:</b>	
866026S	13/16" Square Impact Socket
<b>1" Dr. Six-Point Metric Deep Impact Socket:</b>	
849533	33mm Deep Impact Socket
849535	35mm Deep Impact Socket
849538	38mm Deep Impact Socket
849541	41mm Deep Impact Socket
<b>1" Dr. SAE Deep Thin Wall Impact Socket:</b>	
869534T	1-1/16" Deep Thin Wall Impact Socket
869536T	1-1/8" Deep Thin Wall Impact Socket
869540T	1-1/4" Deep Thin Wall Impact Socket
<b>1" Dr. SAE Deep Budd Wheel Impact Socket:</b>	
869548B	1-1/2" Deep Budd Wheel Impact Socket

Blow Case

9860 g CODE : 026760

2 Sets / 21 Kgs / 0.95 CUFT

## TR-811S 11 Piece 1" Dr. SAE Truck Wheel Impact Socket Set

Item No.	Description
<b>1" Dr. Square Impact Socket:</b>	
866026S	13/16" Square Impact Socket
866030S	15/16" Square Impact Socket
<b>1" Dr. Six-Point Impact Socket:</b>	
867028	7/8" Impact Socket
867030	15/16" Impact Socket
867032	1" Impact Socket
867038	1-3/16" Impact Socket
<b>1" Dr. Deep Thin Wall Impact Socket:</b>	
869534T	1-1/16" Deep Thin Wall Impact Socket
869536T	1-1/8" Deep Thin Wall Impact Socket
869540T	1-1/4" Deep Thin Wall Impact Socket
<b>1" Dr. Deep Budd Wheel Impact Socket:</b>	
869548B	1-1/2" Deep Budd Wheel Impact Socket
<b>1" Dr. Six-Point Deep Impact Socket:</b>	
869556	1-3/4" Deep Impact Socket

Blow Case

8620 g CODE : 023670

2 Sets / 18.5 Kgs / 0.95 CUFT

TR-811M



TR-811MS



TR-811S





- These 1" Dr. impact socket sets are designed for servicing truck wheels.
- The most popular SAE & Metric impact socket sizes for truck wheel fasteners.
- 4-Point impacts sockets for inner Bud-style square fasteners on truck wheels.
- Special 1-1/2" hex deep impact socket is designed for outer cap nuts on Budd-Style truck wheels.
- Deep thin wall impact sockets are designed for truck wheel servicing when removing Dayton Style Lung Nuts that are deeply recessed and where space is very limited.
- Metric impact socket set for servicing tired and wheels on a complete range of European and Japanese trucks with Metric wheel fasteners.



# Truck Wheel Sockets





## #5 Spline Dr. Metric Budd Wheel Sockets

ITEM NO.	A Square	D1 mm	D2 mm	Length mm	Weight g	PCS 	G.W. KGS	CUFT 	CODE @
546017S	17mm	40	60	70	750	24	19.0	0.44	005040
546019S	19mm	42	60	70	750	24	19.0	0.44	005040
546020S	20mm	43	60	70	760	24	19.5	0.44	005040
546021S	21mm	44	60	70	760	24	19.5	0.44	005040

## #5 Spline Dr. SAE Budd Wheel Sockets

ITEM NO.	A Square	D1 mm	D2 mm	Length mm	Weight g	PCS 	G.W. KGS	CUFT 	CODE @
566024S	3/4"	42	60	70	750	24	19.0	0.44	005040
566026S	13/16"	44	60	70	850	24	21.5	0.44	005040
566030S	15/16"	48	60	75	890	24	21.5	0.44	005040
569548B	1-1/2"	58	60	115	1330	10	14.5	0.30	011025

## #5 Spline Dr. Deep Thin Wall Impact Sockets

ITEM NO.	A Hex	D1 mm	D2 mm	Length mm	Weight g	PCS 	G.W. KGS	CUFT 	CODE @
569534T	1-1/16"	40	60	100	850	10	9.5	0.31	007760
569536T	1-1/8"	42	60	100	880	10	10.0	0.31	007760
569540T	1-1/4"	46	60	100	940	10	10.5	0.31	007760

### TR-511S 11 Piece #5 Spline Dr. SAE Truck Wheel Impact Socket Set

- Item No. Description**
- #5 Spline Dr. Square Impact Socket:**
- 566026S 13/16" Square Impact Socket
  - 566030S 15/16" Square Impact Socket
- #5 Spline Dr. Impact Socket:**
- 567028 7/8" Impact Socket
  - 567030 15/16" Impact Socket
  - 567032 1" Impact Socket
  - 567038 1-3/16" Impact Socket
- #5 Spline Dr. Deep Thin Wall Impact Socket:**
- 569534T 1-1/16" Deep Thin Wall Impact Socket
  - 569536T 1-1/8" Deep Thin Wall Impact Socket
  - 569540T 1-1/4" Deep Thin Wall Impact Socket
- #5 Spline Dr. Deep Budd Wheel Impact Socket:**
- 569548B 1-1/2" Deep Budd Wheel Impact Socket
- #5 Spline Dr. Deep Impact Socket:**
- 569556 1-3/4" Deep Impact Socket

 10700 g      CODE : 063670  
 2 Sets / 22.5 Kgs / 0.95 CUFT

### TR-511MS 11 Piece #5 Spline Dr. SAE & Metric Truck Wheel Impact Socket Set

- Item No. Description**
- #5 Spline Dr. Metric Square Impact Socket:**
- 546017S 17mm Square Impact Socket
  - 546021S 21mm Square Impact Socket
- #5 Spline Dr. SAE Square Impact Socket:**
- 566026S 13/16" Square Impact Socket
- #5 Spline Dr. Metric Deep Impact Socket:**
- 549533 33mm Deep Impact Socket
  - 549535 35mm Deep Impact Socket
  - 549538 38mm Deep Impact Socket
  - 549541 41mm Deep Impact Socket
- #5 Spline Dr. SAE Deep Thin Wall Impact Socket:**
- 569534T 1-1/16" Deep Thin Wall Impact Socket
  - 569536T 1-1/8" Deep Thin Wall Impact Socket
  - 569540T 1-1/4" Deep Thin Wall Impact Socket
- #5 Spline Dr. SAE Deep Budd Wheel Impact Socket:**
- 569548B 1-1/2" Deep Budd Wheel Impact Socket

 11800 g      CODE : 072400  
 2 Sets / 24.5 Kgs / 0.95 CUFT

TR-511S



TR-511MS



# Stud Bolt Sockets

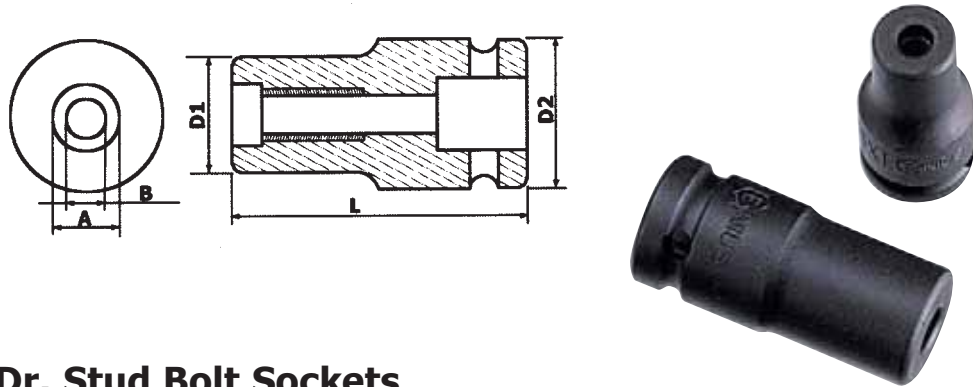

## 3/8" Dr. Stud Bolt Sockets

ITEM NO.	Size mm	A mm	B mm	D1 mm	D2 mm	Length mm	Weight g	PCS 	G.W. KGS	CUFT 	CODE @
306100	M6 X1.00	6.4	5.2	15	20	40	65	200	14.0	0.60	000500
308125	M8 X1.25	8.4	6.9	16	20	40	65	200	14.0	0.60	000500
310125	M10X1.25	10.4	8.9	18	20	46	75	200	16.0	0.60	000500
310150	M10X1.50	10.4	8.6	18	20	46	75	200	16.0	0.60	000500

## 1/2" Dr. Stud Bolt Sockets

ITEM NO.	Size mm	A mm	B mm	D1 mm	D2 mm	Length mm	Weight g	PCS 	G.W. KGS	CUFT 	CODE @
406100	M6 X1.00	6.4	5.2	20	24	52	110	140	17.0	0.44	000500
408100	M8 X 1.00	8.4	7.0	22	24	52	110	140	17.0	0.44	000500
408125	M8 X1.25	8.4	6.9	22	24	52	110	140	17.0	0.44	000500
410100	M10 X 1.00	10.4	9.0	24	24	52	110	140	17.0	0.44	000500
410125	M10 X 1.25	10.4	8.9	24	24	52	110	140	17.0	0.44	000500
410150	M10 X 1.50	10.4	8.6	24	24	52	110	140	17.0	0.44	000500
412125	M12 X 1.25	12.4	10.9	24	24	52	110	140	17.0	0.44	000500
412175	M12 X 1.75	12.4	10.4	24	24	52	110	140	17.0	0.44	000500

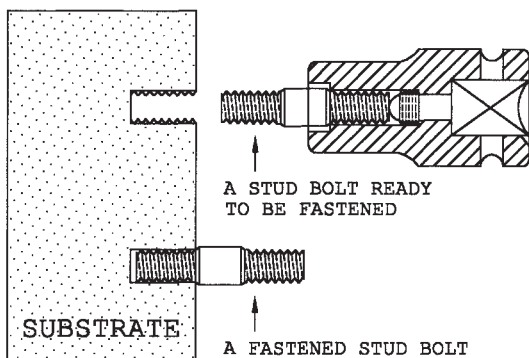

### Features:

- Allows for "turn back" free fastening and unfastening of stud bolts.
- Applications include engine assembly lines and auto repair shops.

# Stud Remover Sockets

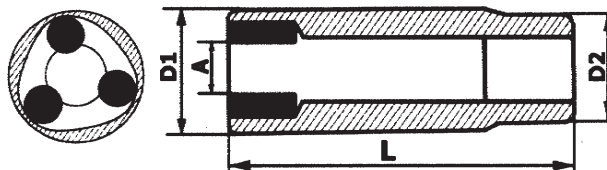

## 1/2" Dr. Metric Stud Remover Sockets

ITEM NO.	A mm	D1 mm	D2 mm	Length mm	Weight g	PCS 	G.W. KGS	CUFT 	CODE @
426306	6	24	21	63	155	150	24.5	0.69	001105
426308	8	24	21	63	155	150	24.5	0.69	001105
427410	10	28	21	74	220	120	27.5	0.52	001130
427412	12	28	21	74	220	120	27.5	0.52	001130
427413	13	28	21	74	220	120	27.5	0.52	001150
427414	14	34	24	74	320	80	26.5	0.52	001200
427416	16	34	24	74	320	80	26.5	0.52	001200

## 1/2" Dr. SAE Stud Remover Sockets

ITEM NO.	A Inch	D1 mm	D2 mm	Length mm	Weight g	PCS 	G.W. KGS	CUFT 	CODE @
486308	1/4	24	21	63	155	150	24.5	0.69	001105
486310	5/16	24	21	63	155	150	24.5	0.69	001105
487412	3/8	28	21	74	220	120	27.5	0.52	001130
487414	7/16	28	21	74	220	120	27.5	0.52	001130
487416	1/2	28	21	74	220	120	27.5	0.52	001150
487418	9/16	34	24	74	320	80	16.5	0.52	001200
487420	5/8	34	24	74	320	80	16.5	0.52	001200



FD-404  
(FD-404M)

### FD-404 4 Piece SAE Stud Remover Socket Set

Item No.	Description
<b>1/2" Dr. Stud Remover Socket:</b>	
486308	1/4" Remover Socket
486310	5/16" Remover Socket
487412	3/8" Remover Socket
487414	7/16" Remover Socket

Metal Box

1030 g      CODE : 005000

20 Sets / 22 Kgs / 0.67 CUFT

### FD-404M 4 Piece Metric Stud Remover Socket Set

Item No.	Description
<b>1/2" Dr. Stud Remover Socket:</b>	
426306	6mm Remover Socket
426308	8mm Remover Socket
427410	10mm Remover Socket
427412	12mm Remover Socket

Metal Box

1030 g      CODE : 005000

20 Sets / 22 Kgs / 0.67 CUFT

Usage as shown below

