

# 3M

## Abrasives

<b>Scotch-Brite™ Hand Pads and Rolls</b>	<b>232</b>	<b>PSA Discs</b>	<b>250</b>
<b>Coated Abrasive Sheets and Rolls</b>	<b>234</b>	<b>Surface Conditioning Discs and Accessories</b>	<b>252</b>
<b>Fibre Discs</b>	<b>236</b>	<b>Abrasive Belts</b>	<b>254</b>
<b>Surface Conditioning Products</b>	<b>237</b>	<b>Surface Conditioning Belts</b>	<b>255</b>
<b>Fibre Grinding Discs</b>	<b>240</b>	<b>Wheels</b>	<b>257</b>
<b>Flap Discs and Accessories</b>	<b>242</b>	<b>Bench Area Products</b>	<b>260</b>
<b>Roloc™ Discs</b>	<b>243</b>	<b>Diamond Grade Products</b>	<b>261</b>
<b>Stikit™ Disc Rolls and Accessories</b>	<b>249</b>	<b>Retail Packs</b>	<b>262</b>

**P**erformance, quality and reliability make 3M a leader with a multitude of abrasive products, including hand pads and rolls, fibre discs, surface conditioning products, abrasive belts, wheels and diamond grade products, to name a few. 3M's coated abrasive sheets are long-lasting sheets of aluminum oxide known for their sharpness and durability. The rugged fibre discs and surface conditioning products can be used in a number of grinding, finishing and cleaning applications. 3M wheels are available in a variety of densities or hardnesses and 3M abrasive belts are ideal for everything from metalworking to woodworking. You will get the job done quicker and easier with 3M abrasive products because of its quality and performance standards.

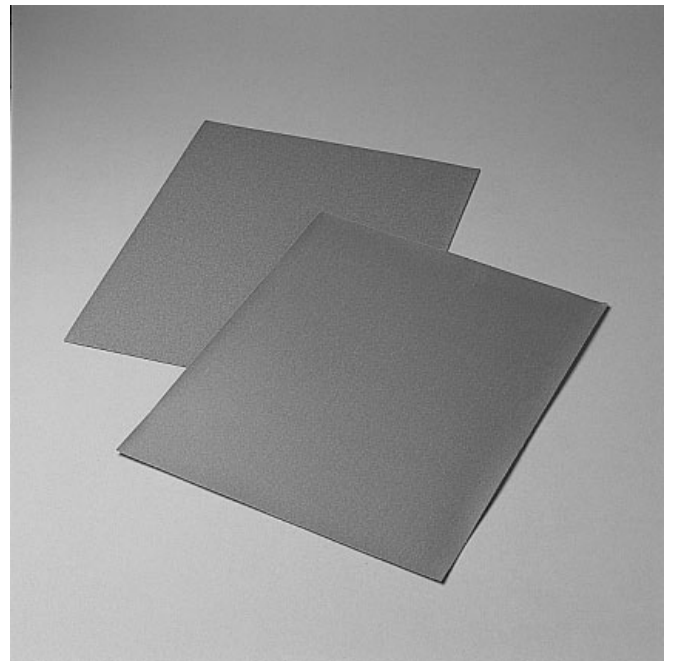

# Scotch-Brite™ Hand Pads and Rolls

## Scotch-Brite Products

For finishing, polishing, deburring, preparing surfaces.



166

### 3M™ Scotch-Brite Hand Pads

- Hand pads that outperform steel wool and wire brushes
- Fast-cutting with consistent finish for surfaces that need to be cleaned or finished by hand
- Pads are non-rusting and can be used with water or solvents
- Your best choice for cleaning and finishing surfaces by hand
- 7447 recommended for best general use



167

### 3M Scotch-Brite General Purpose and Ultra Fine Scuff Sponges

- Three-dimensional abrasive laminated to a sponge
- Ideal for one-step scuffing/cleaning
- May be used wet or dry
- Hand-held size offers convenience, comfort and reduces waste

## Ordering Information for Scotch-Brite Hand Pads

Product Number	UPC (051144-)	Description	Size	In. Unit Pack	Case Qty
<b>Hand Pads and Intro Pack (961 Pad Holder)</b>					
<b>Scotch-Brite Hand Pads</b>					
HP-HP	16983	HP-HP 5440 ULT HD Hand Pad, tan	4" x 6"	40/case	1
HP-HP	16553	HP-HP 6444 Extra Duty HP, brown	6" x 9"	60/case	1
HP-HP	16554	HP-HP 6444B Extra Duty HP, brown	6" x 9"	60/case	1
HP-HP	04050	HP-HP 7440 HVY Duty PAD, tan	6" x 9"	40/case	1
HP-HP	18451	HP-HP 7440B HVY Duty PAD, tan	6" x 9"	40/case	1
HP-HP	16976	HP-HP 7445 Light CLEANSING, white	6" x 9"	60/case	1
HP-HP	04051	HP-HP 7446 Blending Pad, gray	6" x 9"	10/box 40/case	40
HP-HP	04029	HP-HP 7447 Gen Purpose Pad, maroon	6" x 9"	60/case	60
HP-HP	04229	HP-HP 7447B Gen Purpose Pad, maroon	6" x 9"	1/case	1
HP-HP	04028	HP-HP 7448 Ultra Fine Pad, light gray	6" x 9"	20/box 60/case	60
HP-HP	14049	HP-HP 7448B S-ULF Hand Pad, light gray	6" x 9"	60/case	1
HP-HP	24037	HP-HP 8447 Production Hand Pad, maroon	6" x 9"	60/case	1
74	20688	Yellow/Green Sponge	3.5" x 6.25"	20/case	1
96	08293	Scouring Pad	6" x 9"	case	60
<b>Accessories</b>					
961S	17144	Hand Pad Trial Pack	—	9/pack	5
961	09493	Twist-Lok Pad Holder	4" x 6"	10/case	1
<b>Scotch-Brite General Purpose and Ultra Fine Scuff Sponges</b>					
07439	07439*	S/B Clean & Prep Sponge	—	10/each	60
07442	07442*	HP-HP ULF Scuff Sponge	—	10/each	30
HP-HP	07441*	HP-HP G/P Scuff Sponge	—	30/each	30

\*UPC prefix 051131-



168

### Hand Pad Trial Pak Contents:

- 1 Ea. Scrubbing Sponge 74
- 1 Ea. Light Duty Pad 6448
- 1 Ea. Heavy Duty Pad 7440
- 1 Ea. Light Duty Cleansing Pad 7445
- 1 Ea. Blending Pad 7448
- 1 Ea. General Purpose Pad 7447
- 1 Ea. Ultra Fine Pad 7448
- 1 Ea. Production Pad 8447
- 1 Ea. TWIST-LOK Pad Holder 961





169

**3M™ Scotch-Brite™ Sheet Rolls**

- Handy dispenser package
- Tough, highly conformable and sharp-cutting
- The preferred abrasive for cleaning and finishing surfaces by hand
- Colors: Medium (Purple)  
Fine (Gray)

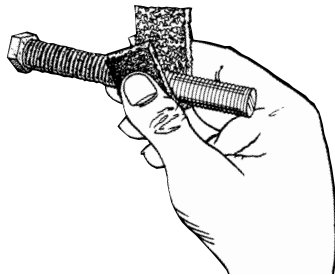

**3M Scotch-Brite Clean and Finish Rolls**

- Rolls of Scotch-Brite material
- 3" strips placed in Mini Mandrel, PN07490, will effectively clean inner dimension of cylinder
- Used by hand for cleaning both male and female threads



170

**3M™ Mini Mandrel No. 935**

- Use with 1" x 1-1/2" pieces of Scotch-Brite material to fit into tight areas
- The overall mandrel length is 2-7/8" with a 1/4" shank

Ordering Information for Scotch-Brite Rolls

Prod. No.	UPC (051144-)	Description	Size	Inner Unit	Case Pack Qty
<b>Scotch-Brite Sheet Rolls</b>					
MX-SR	07521	MX-SR Multi-Flex Abrasive SHT A VFN	8" x 20' 60/RL	1/rls	4
MX-SR	07522	MX-SR Multi-Flex Abrasive SHT S ULF	8" x 20' 60/RL	1/rls	4
<b>Scotch-Brite Sheet Rolls Intro Packs</b>					
2866S	22866	IP-IP Multi-Flex Abrasive SHT S ULF Retail	—	5 pack	20
2867S	22867	IP-IP Multi-Flex Abrasive SHT A VFN Retail	—	5 pack	20
<b>Scotch-Brite Clean and Polish Rolls</b>					
07478	07478	S/B Clean & Finish Roll MED	1" x 10'	5/rls	5
07479	07479	S/B Clean & Finish ROLL CRS	1" x 10'	5/rls	5
07490	07490	935 Mini Mandrel		1 each	1
935	04020	MN-AC 3M Mini Mandrel 935	2-7/8" x 1/4"	5/bag	5
45121	45121	3M Spindle (forked)	1/4" x 1/4" D x Shank	1 each	1
<b>Scotch-Brite Rolls</b>					
CF-RL	00263	CF-RL Clean & Finish Roll F SFN	4" x 30'	3/rls	3
CP-RL	04085	CP-RL Cut & Polish Roll A MED	1" x 30'	12/rls	12



171

**3M Spindle**

- Forked spindle holders for cartridge rolls



170

# Coated Abrasive Sheets and Rolls

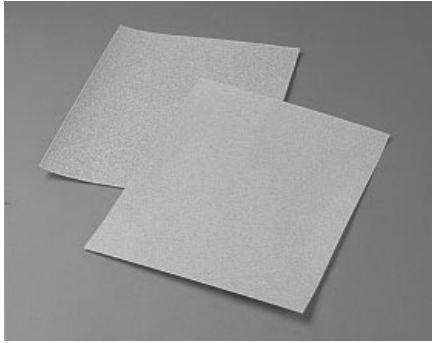

172

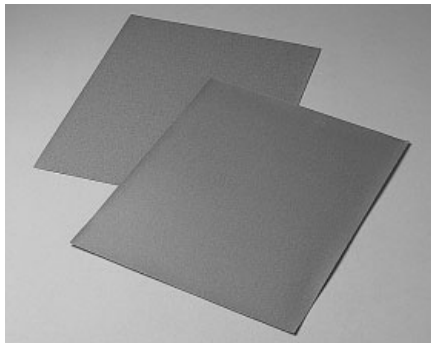

173



174

### 3M™ Production™ Abrasive Sheets

- Universal abrasive
- Long-lasting sheets of aluminum oxide
- Known for sharpness and durability
- Ideal for hand or machine sanding
- Good for wood, metal, paint, plastic and fiberglass

### 3M Wetordry™ Abrasive Sheets

- For efficient cutting and high wear resistance
- Waterproof resin bond resists heat, holds abrasive particles firmly
- Sheets are resistant to oil and water
- Can be used with a lubricant to reduce clogging

### 3M Emery Abrasive Sheets

- For general purpose metal sanding
- Light clean up work and rust removal

### 3M Elek-Tro-Cut™ and Blue Grit Utility Cloth Sheets

- Tough aluminum oxide bonded to cloth
- Flexible, rust removal and sanding
- Good for all general maintenance work

### 3M Good Utility Shop Rolls

- Abrasive rolls in 1", 2" widths x 164 ft.
- Designed for versatile applications in many shops

### 3M Blue Grit Utility Cloth

- Toughest, most durable
- Resists moisture, conformable
- Best general purpose sanding
- Removes rough spots
- Deburring and cleaning metal surfaces

- 3M 341T 3M Blue Grit Utility Cloth X Wt.
- 3M 311T 3M Blue Grit Utility Cloth J Wt.
- 3M 241K Three-M-ite™ Elek-Tro-Cut™ X Wt.
- 3M 211K Three-M-ite Elek-Tro-Cut™ Cloth J Wt.
- 3M 001K Crystal Bay™ Crocus Cloth
- 3M 011K Crystal Bay Emery Cloth

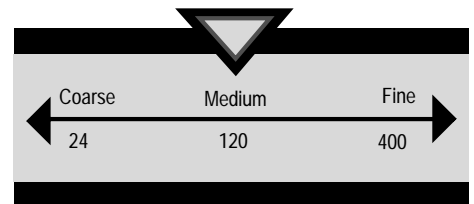

## Ordering Information for Coated Abrasive Sheets

Size	Prod. I.D.	Min. Pkg./Case	Grade and UPC No. (05114-)							
			36X	40X	50X	60X	80J	100J	120J	150J
9" x 11"	341T/311T	50/250		02463	02462	02461	02460	02459	02458	02457
			180J	220J	240J	280J				
			02456	02455	02454	02453				
9" x 11"	241K/211K	50/250	36X	40X	50X	60X	80J	100J	120J	150J
			02414		02412	02411	02410	02409	02408	02407
			180J	220J	240J	280J	320J	400J	500J	
			02406	02405	02404	02403	02402	12501	12500	
			36X	40X						
9" x 11"	001K	50/250		02435						
			CRS	MED	FIN					
9" x 11"	011K	50/250	02433	02432	02431					

**3M™ 341T 3M Blue Grit Utility Cloth X Wt.**  
**3M 311T 3M Blue Grit Utility Cloth J Wt.**  
**3M241K Three-M-ite™ Elek-Tro-Cut™ X Wt.**  
**3M 211K Three-M-ite Elek-Tro-Cut Cloth J Wt.**  
**3M 001K Crystal Bay™ Crocus Cloth**  
**3M 001K Crystal Bay Emery Cloth**  
**3M 221T**

Ordering Information for Coated Abrasive Rolls

Size	Prod. I.D.	Min. Pkg./Case	Grade and UPC No. (051144-)										
			40X	50X	60X	80J	100J	120J	150J	180J	220J	240J	280J
1" x 50 yds.	341T/311T	1/5		05112	05111	05110	05109	05108	05107	05106	05105	05104	05103
1 1/2" x 50 yds.	341T/311T	1/5		05127	05126	05125	05124	05123	05122	05121	05120	05119	05118
2" x 50 yds.	341T/311T	1/5	05143	05142	05141	05140	05139	05138	05137	05136	05135	05134	05133
1" x 50 yds.	241K/211K	1/5			05011	05010	05009	05008	05007	05006	05005	05004	05003
			320J	400J	500J								
			05002	05001	05000								
1 1/2" x 50 yds.	241K/211K	1/5	05032	05031	05030	05029	05028	05027	05026	05025	05024		
			320J	400J	500J								
			05022	05021	05020								
2" x 50 yds.	241K/211K	1/5	36X	50X	60X	80J	100J	120J	150J	180J	220J	240J	280J
			05054	05052	05051	05050	05049	05048	05047	05046	05045	05044	05043
			320J	400J	500J								
			05042	05041	05040								

**3M™ 110N, 130N, 140N A, C, D Wt.**  
**Grades 50-280**

Ordering Information for Garnet Abrasive Sheets

Size	Prod. I.D.	Min. Pkg./Case	Grade and UPC No. (05114-)										
			50	60	80	100	120	150	180	220	240	280	
9" x 11"	140N (D Wt.)	50 slv/500	10035	10034	10033								
	130N (C Wt.)	100 slv/1000				10032	10031	10030					
	110N (A Wt.)	100 slv/1000				10006	10005	10004	10003	10002	10001	10000	

**3M 326U, 336U, 346U A, C, D Wt.**  
**Grades 36-220**

Ordering Information Production™ Abrasive Sheets

Size	Prod. I.D.	Min. Pkg./Case	Grade and UPC No. (05114-)										
			36	40	50	60	80	100	120	150	180	220	
9" x 11"	346U (D Wt)	50 slv/250	02119										
		50 slv/250		02118*	02117	02116	02115						
	336U (C Wt)	50 slv/1000						02114	02113	02112			
	326U (A Wt)	50 slv/1000									02104	02103	

\* Prod. I.D. -346U

**3M 413Q Wetordry™ Tri-M-ite Paper A Wt.**  
**3M 431Q Wetordry Tri-M-ite Paper C Wt.**

Ordering Information for Wetordry Abrasive Sheets

Size	Prod. I.D.	Min. Pkg./Case	Grade and UPC No. (05114-)											
			60	80	100	120	150	180	220	240	280	320	360	400
9" x 11"	413Q	50 slv/500							02007			02004	02003	02002
		50 slv/250									02006	02005		
	431Q	50 slv/500	02019							10699		10697		10695
		50 slv/250		02018	02017	02016	02015	02014						



# Fibre Discs

Information about Fibre Disc and Surface Conditioning To Get Your Started...

Rough  
Grinding

Weld  
Removal

Scale  
Removal

Blending

Finishing

Surface  
Prep

Weld  
Cleanup

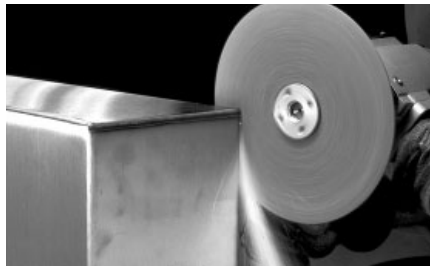

175

## 3M™ 785C

Grinds cool with a high rate of cut to give optimum performance on stainless steel. This disc contains a blend of 3M Cubitron™ abrasive grain and aluminum oxide mineral with grinding aid. Also suitable for grinding carbon steel or aluminum.



176

## 3M 281C

Aluminum oxide fibre disc. Can be used in most general-purpose applications.



177

## 3M 747D Abrasive Flap Discs

Used for offhand grinding and finishing of metal. Provides consistent rate of cut and long life performance that improves quality and lowers cost.

## 3M Scotch-Brite™ SE Surface Conditioning Discs

“SE” surface conditioning discs feature a coarser, tougher, more aggressive web construction than original surface conditioning discs. For heavier deburring and finishing applications.

## 3M Scotch-Brite Surface Conditioning Discs

Scotch-Brite surface conditioning discs are best for finishing, cleaning and light deburring on flat metal surfaces.



178

## 3M Scotch-Brite Coating Removal Discs (Hook and Loop)

Rugged non-loading open web is designed to tackle your toughest cleaning jobs like stripping paint and coatings from metal surfaces, preparing surface for re-coating and general plant maintenance.



179

## 3M Bristle Discs

Ideal for safely cleaning and stripping paint and a wide variety of other substances off of metal. Benefits include consistent wear, uniform finish, and lack of loading.

# Surface Conditioning Products









## Surface Finishes Generated by Surface Conditioning

Mineral Type	Grade	Finishes Generated (Micro-Inch Range)		Coated Abrasive Grade Equivalent
		Aluminum	Stainless Steel	
A	Coarse	130-150	62-72	80-150
A	Medium	80-100	32-40	150-180
A	Very Fine	16-35	6-12	220-320
S	Super Fine	8-12	4-6	320-600

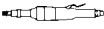
### Safety, to protect yourself.

Read and follow instructions for use. Always use appropriate protective glasses, face shields and body protection. Do not exceed maximum operating RPM. Use guards provided with machine. Follow safety operation procedures posted in work areas.

### Guide to Product Selection by Application and Tool

Tool	Cleaning	Deburring	Polishing	Finishing
Off Hand 	7447, 6448 Hand Pads	7440, 6444 Hand Pads	7448, 7445 Hand Pads	7446, 7447 Hand Pads
Drill Motor 	Clean and Strip Discs High Strength Discs A MED	Unitized Wheels High Strength Discs A VFN	High Strength Discs A VFN	High Strength Discs A MED
Straight Grinder 	Clean and Strip Discs High Strength Discs A MED	EXL Wheels	-	Surface Conditioning Belts (with Expander Wheel)
Die Grinder 	Unitized Wheels	Unitized Wheels	Unitized Wheels	-
Right Angle Grinder 	Surface Conditioning Discs	Surface Conditioning Discs	Surface Conditioning Discs	Surface Conditioning Discs
Mini-Angle Grinder 	Clean and Strip Cup Wheels	-	Clean and Strip Cup Wheels	-
Right Angle Die Grinder 	Roloc™ Surface Conditioning Discs Roloc Unitized Wheels	Roloc Surface Conditioning Discs Roloc Unitized Wheels	Roloc Surface Conditioning Discs Roloc Unitized Wheels	Roloc Surface Conditioning Discs
Belt Sander 	Surface Conditioning Belts	Surface Conditioning Belts	Surface Conditioning Belts	Surface Conditioning Belts
Bench Motor 	-	EXL Wheels	-	-

## Performance Advantages Over Competitive Products

Competitive Product	Scotch-Brite™ Products			
	Cleaning	Deburring	Polishing	Finishing
Steel Wool	Leaves No Metal Fines No Carbon Contamination on Surface	-	Leaves No Metal Fines No Carbon Contamination on Surface	Leaves No Metal Fines No Oil Contamination
Sandpaper: Sheets, Rolls, Belts and Flap Wheels	Work Piece Protected Consistent Finish Resists Loading	Work Piece Protected No Secondary Burns Uniform Radius	Work Piece Protected No Secondary Burns	Consistent Finish Resists Loading Work Piece Protected
Wire Brushes	Removes all Surface Contaminants Doesn't Fling Wires	Complete Burr Removal Doesn't Fling Wires Uniform Radius	-	-
Buff and Compound		Cleaner/Faster	Cleaner/Faster	Cleaner/Faster
Tampico and Bristle	Faster Thorough Cleaning	Better Radiused Edge	-	-
Files, Burrs and Scrapers	Won't Damage Piece Faster	Won't Damage Piece Faster	-	-
Set-Up Wheels	-	No Undercutting Cleaner	Cleaner/Faster Less Set-Up Time	Cleaner/Faster Less Set-Up Time
Sand Blasting	No airborne Particles to be contaminated	-	-	-
Rubber Bonded Wheels	Cleaner Finish Faster	Cleaner Finish Faster	Cleaner Finish Faster	-

### Factors Affecting Performance of Surface Conditioning Products

#### Product Surface Speed

Because product speed has a significant effect on performance (cut, life, and finish), it is important to select the proper speed for a particular operation and work piece.

Generally, low speeds are desired for generating very uniform satin finishes, for finishing aluminum alloys without lubricants and for use on composite or other soft material applications. High speeds are recommended when it is desired to remove or blend surface imperfections. This high speed will result in faster cut along with finer finishes.

#### Recommended Operating Speeds

Decorative Finishing	500 - 3000 SFPM
Composites / Soft Materials	1200 - 2700 SFPM
Cleaning and Conditioning	2000 - 5000 SFPM
Prepolishing	2000 - 7000 SFPM
Oxide Removal	4500 - 6500 SFPM
Deburring	5000 - 6500 SFPM
Blending / Polishing	6000 - 8000 SFPM
Cutdown Prior to Buffing	7000 - 8500 SFPM

#### Work Pressure

It is important that adequate pressure be used to generate the desired cut, finish, and life. Excess pressure, however, can result in decreased product life. Scotch-Brite™ wheels operate under work pressures of 10 to 40 pounds per inch of width. In the case of harder (6 - 9 density) products, high pressures are usually necessary to gain the full benefit of the wheel.

#### Feed Speed (Dwell Time)

Feed speed is directly related to product life, finish and cut. Lower feed speed means longer dwell time and, thus, more work can be done on the workpiece. When an operation is set up an attempt should be made to use the fastest feed speed possible to obtain the desired results. This will give the best economic result from the standpoint of product life.

In general, if product speed remains constant, fast feed speeds increase scratch length and, conversely, slow feed speeds shorten scratch length. This technique can be used to generate a particular decorative finish.

#### Oscillation

In many cases, such as decorative finishing and cleaning, it is desirable to incorporate an oscillatory motion for the purpose of increasing cut, breaking up directional scratch, and producing a uniform finish. A good starting point is 150 CPM (cycles per minute) at a stroke of 3/8 inches. This may be varied depending on the particular result desired.

In off-hand operations, moving the part from side to side will provide an oscillating action and more uniform finish.

#### Lubricant - Coolant

Coolants, like water and some water soluble oils, reduce heat resulting in longer product life and greater cut. In the case of most oils or tallow lubricants, surface roughness can be reduced. The higher viscosity lubricants produce lower surface roughness, i.e., grease produces a finer surface finish than oil. In automatic or semi-automatic operations, it is desirable to use lubricants or coolants whenever possible.



**Product Hardness (Density)**

3M™ wheels are available in a number of densities or hardnesses. Generally, the softer products, 2, 3, 4, and 5 density, are used for decorative finishing. They will conform more readily to surface contours along with generating a more uniform finish. The harder products, 6, 7, 8 and 9 density, are to be used for the more difficult blending, cleaning and deburring operations.

**Surface Speed Conversion Chart**

R.P.M. at Arbor or Spindle	Diameter of Wheels								
	2	4	6	8	10	12	14	15	18
100	52	104	157	207	260	314	364	419	471
200	105	208	314	414	520	628	728	838	942
300	157	312	471	621	780	942	1092	1257	1414
400	209	416	628	828	1040	1256	1456	1676	1885
500	262	520	785	1045	1310	1570	1820	2094	2356
600	314	630	940	1255	1570	1885	2195	2513	2827
700	367	735	1100	1465	1835	2200	2560	2932	3299
800	419	837	1256	1675	2094	2513	2932	3351	3770
900	471	942	1413	1885	2356	2827	3298	3770	4241
1000	524	1047	1570	2094	2618	3141	3665	4189	4712
1100	576	1152	1727	2304	2880	3455	4031	4608	5184
1200	628	1256	1884	2513	3142	3769	4398	5027	5655
1300	681	1361	2042	2723	3404	4084	4764	5445	6126
1400	733	1466	2199	2932	3666	4398	5131	5864	6597
1500	785	1571	2356	3142	3927	4712	5497	6283	7069
1600	838	1675	2513	3351	4189	5026	5864	6702	7540
1700	890	1780	2670	3560	4451	5340	6230	7121	8011
1800	942	1885	2827	3770	4713	5650	6597	7540	8482
1900	995	1989	2984	3979	4975	5969	6963	7959	8954
2000	1047	2094	3141	4189	5236	6283	7330	8378	9425
2100	1100	2199	3298	4398	5498	6597	7696	8796	9896
2200	1152	2304	3455	4608	5760	6911	8063	9215	10367
2300	1204	2408	3612	4817	6022	7225	8429	9634	10839
2400	1257	2513	3770	5027	6284	7540	8796	10053	11310
2500	1309	2618	3927	5236	6545	7854	9162	10472	11781
2600	1361	2722	4084	5445	6807	8168	9529	10891	12252
2700	1414	2827	4241	5655	7069	8482	9895	11310	12723
2800	1466	2932	4398	5864	7331	8796	10262	11729	13195
2900	1518	3037	4555	6074	7592	9110	10629	12148	13666
3000	1571	3141	4712	6283	7854	9425	10996	12566	14137
3200	1676	3351	5026	6702	8378	10053	11729	13404	15080
3400	1780	3560	5340	7121	8901	10681	12462	14242	16022
3600	1885	3769	5654	7539	9425	11309	13193	15080	16965
3800	1990	3979	5969	7958	9948	11938	13927	15917	17907
4000	2094	4188	6283	8377	10472	12566	14661	16755	18850

# Fibre Grinding Discs



180

## 3M Grinding Discs

- Good for maintenance and repair
- Fibre discs designed for electric grinders or air grinders

## 3M Regalite™ Grinding Discs

- Tough ceramic and aluminum oxide mineral
- Built in grinding aid to improve grinding on harder metals
- Tough fibre backing

## 3M™ 785C Regalite™ Polycut Fibre

### Ordering Information for Regalite™ Grinding Discs

Size	Prod. I.D.	Min. Pkg./Case	Grade and UPC No. (051144-)						
			24	36	50	60	80	P100	P120
4 1/2" x 7/8"	785C	100	-	80660	80661	80662	80663	-	-
5" x 7/8"	785C	100	-	13975	13976	13977	13978	80654	80655
5" x 7/8"	785C	25/100	13931	13930	13928	-	13926	-	-
7" x 7/8"	785C	100	-	13967	13968	13969	13970	80656	80657
7" x 7/8"	785C	25/100	13937	13936	13934	13933	13932	-	-
9 1/8" x 7/8"	785C	25/100	13943	13942	13940	13939	13938	-	-

## 3M 281C Fiber Disc

## 3M 381C - 3M Type C Type XY

### Ordering Information for 3M Grinding Discs

Size	Prod. I.D.	Min. Pkg./Case	Grade and UPC No. (051144-)							
			16	24	36	50	60	80	100	120
4" x 5/8"	281C	25	-	85950	85951	-	85955*	85956*	85957*	85958*
4 1/2" x 7/8"	281C	25	-	88959	85960	85961	85962	85963	85964*	85965*
5" x 7/8"	281C	25	-	85966	85967	85968	85969	85970	85971	85972
7" x 7/8"	281C	25	-	85973	85974	85975	85976	85977	85978	85979
4 1/2" x 7/8"	381C	25/100	-	77595	77596	77597	77598	77599	77600	77601
5" x 7/8"	381C	25/100	88725	81369	81372	81375	01727	20054	20053	20052
7" x 7/8"	381C	25/100	01745	81370	81373	81376	01741	01740	01739	01738
9 1/8" x 7/8"	381C	25/100	01767	81371	81374	81377	01763	01762	01761	01760

\* Kut stock items

### Fibre Disc Pad Accessories

- Get faster cut and longer life; use with the correct backup

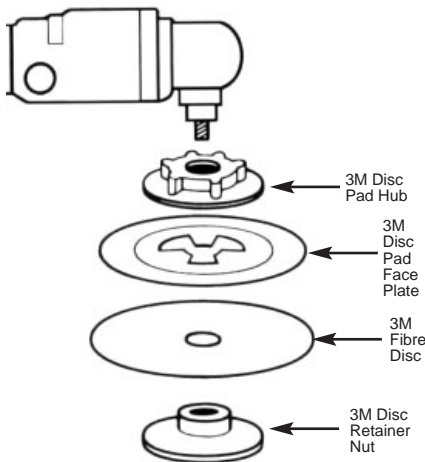

### Ordering Information for 3M™ Disc Pad Face Plates – Ribbed

Diameter	Hardness	Max. Oper. RPMs	Min. Pkg./Case	UPC (051144-)
5"	Extra hard – red	12,000	1/25	81732
5"	Hard-black	12,000	1/25	81733
5"	Medium-gray	12,000	1/25	81734
5"	Soft-white	12,000	1/25	81735
7"	Extra hard – red	8,500	1/25	80514
7"	Hard-black	8,500	1/25	80515
7"	Medium-gray	8,500	1/25	80516
7"	Soft-white	8,500	1/25	80517
9"	Extra hard – red	6,500	1/25	81728
9"	Hard-black	6,500	1/25	81729
9"	Medium-gray	6,500	1/25	81730
9"	Soft-white	6,500	1/25	81731

### Ordering Information for 3M Disc Pad Hubs and Face Plates

Diameter	Hardness	Max. Oper. RPMs	Min. Pkg./Case	UPC (051144-)
<b>Hubs</b>				
2 1/2" Dia. 5/8"-11 use with all sizes		-	1/10	45205
2 1/2" Disc Pad Hub-Short Shaft Tools		-	1/10	88743*
4 1/2" Dia. 5/8"-11 use with sizes 7", 8" & 9"		-	1/10	45190
<b>Face Plates</b>				
4 1/2"	Hard – black	13,000	1/10	14270
4 1/2"	Medium – gray	13,000	1/10	13325
5"	Hard – black	12,000	1/10	45206
5"	Medium – gray	12,000	1/10	45207
5"	Soft – white	12,000	1/10	45208
7"	Hard – black	8,500	1/10	45192
7"	Medium – gray	8,500	1/10	45193
7"	Soft – white	8,500	1/10	45194
9"	Hard – black	6,500	1/10	45195
9"	Medium – gray	6,500	1/10	45196
9"	Soft – white	6,500	1/10	45197

\*Kut stock items

### 3M Disc Holder Adaptors No. 9

Ext. Thread	Int. Thread	Min.Pkg/Case	UPC (048011-)
5/8"-11	M10 - 1.25	1/10	22971
5/8"-11	M10 - 1.50	1/10	22972
5/8"-11	3/8" -24	1/10	22970

### 3M Fibre Disc Pad Hub and Retainer Nut

Diameter x Thread Size	Min.Pkg./Case	UPC (051144-)
4 1/2" x 5/8"-11	1/10	05633

### 3M Disc Retainer Nuts

Length x Thread Size	Min.Pkg./Case	UPC (051144-)
5/8" x 5/8"-11	1/10	05620
1/2" x 5/8"-11	1/10	05621
3/8" x 5/8"-11	1/10	05622
<b>Thread Length</b>		
1/2" x 5/8"-11	1/10	05632



181

**3M™ Abrasive Flap Discs 747D  
(Ceramic Aluminum Oxide -  
Type 27)**

- Angled for better surface coverage
- Consistent rate of cut
- Improves quality and lowers cost



Ceramic Aluminum Oxide - Type 27



182

**3M Flap Discs 563D  
(Alumina Zirconia - Type 29)**

- Off hand grinding and finishing of metals
- Angled for much better surface coverage
- Provides a consistent rate of cut for superior finish
- Provides long-life performance
- Lower cost



Alumina Zirconia - Type 29

Ordering Information for 3M Abrasive Flap Discs

Size	Prod. I.D.	Min. Pkg./Case	Grade and UPC (051111-)				
			36X	50X	60X	80X	120X
4 1/2" x 7/8"	747D	10	49613	49614	49615	49616	49617
			36Y	40Y	60Y	80Y	120Y
			50467	50468	50469	50470	50471
7" x 7/8"	747D	5	49608	49609	49610	49611	49612
			36Y	40Y	60Y	80Y	120Y
			50472	50473	50474	50475	50476

**Maximum Operating RPMs:**

- 4 1/2" dia. – 13,300
- 7" dia. – 8,600

Ordering Information for Flap Discs Accessories

Product Number	UPC (051144-)	Description	Size	Inner Unit Pack	Case Qty
88764	88764	Flap Disk Adapter Nuts	3/8 - 11	2/pack	10
88763	88763	Flap Disk Adapter Nuts	1/2 - 13	2/pack	10
88765	88765	Flap Disk Adapter Nuts	5/8-11	2/pack	10
T-27	88769	Flap Disk Holder	4" x 5/8-11	box	6

# Roloc™ Discs

Provide a fast, efficient method for deburring, blending, finishing, removing tool marks and die polishing on all types of metals. Resist loading and shelling under severe operating conditions. They lock securely in place with just a half twist...a half twist and it's off. Each disc is color coded by grade. Ideal for use on air tools (right angle and straight) and on flexible shaft grinders. Additionally, Roloc discs and pads feature three different types of fastening systems to accommodate most any stock that you may currently have on hand.

## Easy to mount...easy to change

3M™ coated abrasive and Scotch-Brite™ Roloc surface conditioning discs feature a threaded male button attached to the back of each disc for quick and easy mounting to a Roloc disc pad. With a quick half-turn, the disc is locked securely in place for the life of the disc. Each button or disc is color coded to designate grade.

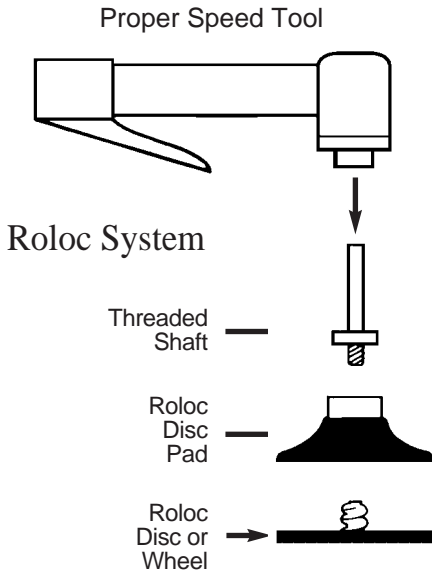

**Roloc™ Discs**

3M™ Roloc Disc Button Color/Grade Chart

16	Blue
20	White
24	Black
36	Purple
40	Maroon
50	Green
60	Orange
80	Yellow
100	Blue
120	White
150	Black
180	Purple
220	Maroon
240	Green
280	Orange
320	Yellow
400	Blue
500	White

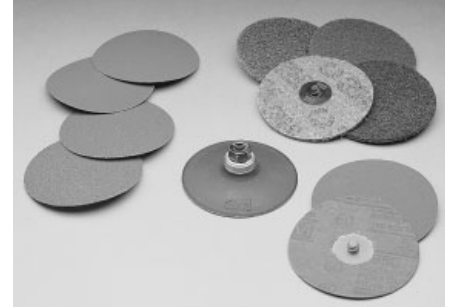

183





184

**Roloc System**

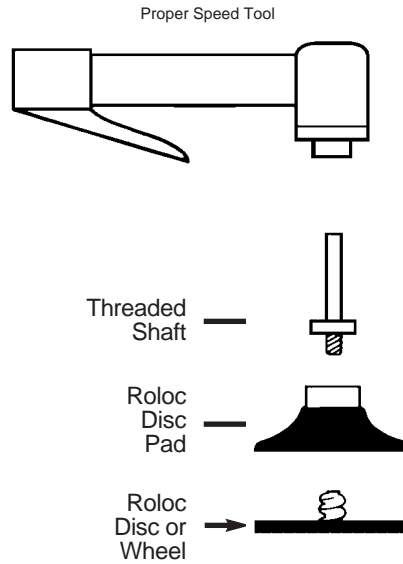

**3M™ Roloc Discs**

- Fast, efficient abrasive discs for grinding metal

**3M Regalite™ Roloc Discs**

- Tough ceramic and aluminum oxide mineral
- Built-in grinding aid to improve grinding on harder metals
- Tough fiber backing

3M 361F Three-M-ite™ Resin Bond Cloth YF Wt. Grades 24–150, XF Wt. P180–P320

Size	Prod. I.D.	Min. Pkg./Case	Grade and UPC (051144-)											
			24	36	40	50	60	80	P100	P120	P150	P180	P240	P32
1" dia.	361F	50/500	11413	11412	-	11411	11417	11416	11415	11414	-	-	-	-
2" dia.	361F	50/200	11000	22398	-	22399	22400	22401	22402	22403	14559	13873	11419	-
3" dia.	361F	50/200	22392	22393	-	22394	22395	22404	22405	22406	82244	-	11418	-
4" dia.	361F	25/100	-	76429	-	-	11421	11420	-	-	-	-	-	-

**Ordering Information for Roloc Introductory Packs**

Prod. I.D.	Contents	Packs/Case	UPC (051144-)
984WS	984C Regal Resin Bond Fibre Roloc Discs 4" Dia. 1 ea. 36, 1 ea. 50, 1 ea. 60, 1 ea. 80 Roloc Surface Conditioning Discs 4" Dia. 1 ea. A VFN (Blue), 1 ea. A MED (Maroon), 1 ea. A CRS (Brown) Roloc SE Surface Conditioning Disc 4" Dia. 1 ea. A CRS (Brown/Blue) Roloc Disc Pad 4" x 5/8" - 11 1 ea. hard	5	83490
785SS	785C Regalite Polycut Resin Bond Fibre Roloc Discs 4" Dia. 1 ea. 36, 1 ea. 50, 1 ea. 60, 1 ea. 80, 1 ea. 100, 1 ea. 120 Roloc Surface Conditioning Discs 4" Dia. 1 ea. A VFN (Blue), 1 ea. A MED (Maroon), 1 ea. A CRS (Brown) Roloc SE Surface Conditioning Discs 4" Dia. 1 ea. A CRS (Brown/Blue) Roloc Disc Pad 4" x 5/8" - 11 1 ea. hard	5	83491

## Ordering Information for 3M™ 461F Tri-M-ite™ Resin Bond Cloth YF Wt.

Size	Prod. I.D.	Min. Pkg./Case	Grade and UPC (051144-)											
			24	36	40	50	60	80	P100	P120	P150	P180	P240	P32
2" dia.	461F	50/200	-	-	-	-	12956	12954	-	-	-	-	-	-
3" dia.	461F	50/200	-	12958	-	-	12957	12955	-	-	-	-	-	-

Ordering Information for 3M 777F Regalite™ Polycut™ Resin Bond Cloth YF Wt.  
3M 785C Regalite Polycut Fibre

Size	Prod. I.D.	Min. Pkg./Case	Grade and UPC (051144-)							
			24	36	40	50	60	80	P100	P120
1" dia.	777F	50/500	-	76622*	-	76623	76624	76625	-	80510
1 1/2" dia.	777F	50/500	-	76626	-	76627	76628	14660	-	80511
2" dia.	777F	50/200	-	76629	-	76630	76433	14661	80508	80512
3" dia.	777F	50/200	-	76631	-	76632	76633	76634	80509	80513
4" dia.	785C	25/100	-	83690	-	83691	83692	83693	83694	83695

\*Kut stock items

**3M™ 977F Regalloy Resin Bond Cloth**  
**3M™ 963G Regal™ Resin Bond Cloth YN Wt. Grades 24-80**  
**XF Wt. Grades P100 and P120**  
**3M™ 984C Regal Resin Bond Fibre**  
**All 4" Products**

## Ordering Information for Roloc™ Discs

Size	Prod. I.D.	Min. Pkg./Case	Grade and UPC (051144-)							
			24	36	40	50	60	80	P100	P120
1" dia.	963G	50/500	-		-	11422	11428	11427	-	11425*
2" dia.	963G	50/200	11113	11112	-	11111	11110	11109	11107	11106
2" dia.	977F	50/200	-	83587	-		83588	83589	-	-
3" dia.	963G	50/200	11108	11105	-	11104	11103	11102	11101	11100
3" dia.	977F	50/200	-	83590	-		83591*	83592	-	-
4" dia.	984C	25/100	-	83696	-	83697	83698	83699	-	-

\*Kut stock items

## Ordering Information for 3M 983C Regal Resin Bond Fibre Grades 36, 60 and 80

Size	Prod. I.D.	Min. Pkg./Case	Grade and UPC (051144-)						
			24	36	40	50	60	80	P100
2" dia.	983C	50/200	-	22352	-	-	22353	22354	-
3" dia.	983C	50/200	-	22349	-	-	22350	22351	-



185

### 3M™ Roloc™ Surface Conditioning Discs

- Scotch-Brite™ Roloc discs leave a surface suitable for painting/coating
- Used for removal of light rust, oxides and coatings

### Roloc SE Surface Conditioning Discs

- Scotch-Brite “SE” surface conditioning products feature a coarser, tougher, more aggressive, abrasive impregnated web construction than regular Scotch-Brite surface conditioning products
- Used for heavy deburring, cleaning and finishing applications

## Ordering Information for Roloc Surface Conditioning Discs

Size	Max. Oper. RPMs	Discs/Case	Mineral Type/Grade UPC (048011-)			
			A CRS	A MED	A VFN	S SFN
1" x NH	30,000	200	15393	15392	15391	-
2" x NH	25,000	200	05528	05527	05523	05522
3" x NH	18,000	100	05532	05531	05530	05529
4" x NH	12,000	100	12954	12953	12952	-

## Ordering Information for Roloc SE Surface Conditioning Discs

Size	Max. Oper. RPMs	Discs/Case	Mineral Type/Grade UPC (048011-)	
			A CRS	A MED
2" x NH	25,000	200	18081	18471
3" x NH	18,000	25	18082	18472
4" x NH	12,000	25	18243	-

## Ordering Information for Roloc Surface Conditioning Introductory Packs

Prod. I.D.	Contents	Packs/Case	UPC (051144-)
985S	Roloc Surface Conditioning Discs - 2" Dia. 2 ea. S SFN (Gray), 2 ea. A VFN (Blue), 2 ea. A MED (Maroon), 2 ea. A CRS (Brown)	5	18254
	Roloc Surface Conditioning Discs - 3" Dia. 2 ea. S SFN (Gray), 2 ea. A VFN (Blue), 2 ea. A MED (Maroon), 2 ea. A CRS (Brown)	5	18254
	Roloc Disc Pads 1 ea. 2" Medium, 1 ea. 3" Medium, 2 ea. 1/4" Threaded Shaft	5	18254



186

### 3M™ Roloc™ Bristle Discs

- Ideal for cleaning, finishing, blending and deburring
- Used on corners, welds and for rivet cleaning on all areas where conformability is required
- Eliminate dangerous flying wires

### Roloc Radial Bristle Discs

- Remove adhesive, paint and other coatings
- Deburr and blend
- Clean and prepare surfaces before and after welding



187

## Ordering Information for Roloc Bristle Discs

Size	Trim (T=Tapered)	Min. Pkg./Case	Max. Oper. RPM's	Grade and UPC (048011-)		
				50	80	120
1" dia.	5/8"	20/80	30,000	18698	18706	18710
2" dia.	1/2"	10/40	25,000	18730	18732	18537
	5/8"T	10/40	25,000			18733
3" dia.	1/2"	10/40	18,000	18734	18736	18538
	5/8"T	10/40	29,000			18737
4.5" dia.	5/8"-11 Thread	5/10	12,000	24241	24242	24243
7" dia.	5/8"-11 Thread	5/5	6,000	07577	07578	-

## Ordering Information for Roloc Radial Bristle Discs

Size	Trim (T=Tapered)	Min. Pkg./Case	Max. Oper. RPM's	Grade and UPC (048011-)		
				50	80	120
3" dia.	-	10/40	25,000	24276	24277	24278

## Ordering Information for Roloc Discs Introductory Packs

Prod. I.D.	Contents	Inner Unit Pack	Packs/Case	UPC (048011-)
982BS	Roloc Bristle Disc, 2" x 1/2" trim, 50x, 80x, 120x Roloc Disc Pad Holder, 2", hard	2 ea. 1 ea.	5	18696
982RS	3M 777F Roloc Discs, 2", 60YF, 80YF, 120YF Roloc Surface Conditioning Discs, 2", ACRS, AMED, AVFN, SSFN Roloc SE Surface Conditioning Discs, 2", ACRS Roloc Bristle Disc, 2" x 5/8" tapered, 50x, 80x, 120x Roloc EXL Unitized Wheels, 2", 2SFIN, 6AMED, 8ACRS Roloc Disc Pad Holder, 2", Hard	3 ea. 2 ea. 2 ea. 1 ea. 2 ea. 1 ea.	5	18694
983RS	3M 777F Roloc Discs, 3", 60YF, 80YF, 120YF Roloc Surface Conditioning Discs, 3", ACRS, AMED, AVFN, SSFN Roloc SE Surface Conditioning Discs, 3", ACRS Roloc EXL Unitized Wheels, 3", 2SFIN, 6AMED, 8ACRS Roloc Bristle Disc, 3" x 5/8" tapered, 50x, 80x, 120x Roloc Disc Pad Holder, 3", Hard	3 ea. 2 ea. 2 ea. 1 ea. 2 ea. 1 ea.	5	18695

**Roloc Disc Pads**

- Rubber back-up pads available in different diameters and degrees of hardness for various grinding applications

**EXL Roloc Unitized Wheels**

- Strong, efficient products for edge deferring and finishing

## Ordering Information for 3M™ Roloc Disc Pads

Diameter	Hardness	Max. Oper. RPM's	UPC (051144-)
1"	Medium	30,000	45101
2"	Extra Hard	25,000	45097
2"	Hard	25,000	45096
2"	Medium	25,000	45095
2"	Soft	20,000	45094
3"	Extra Hard	20,000	45093
3"	Hard	20,000	45091
3"	Medium	18,000	45092
3"	Soft	15,000	45090
4" 5/8"-11	Hard	12,000	83489
4"	Medium	12,000	45179
1/4" Threaded Shaft	-	-	45102

## Ordering Information for EXL Roloc Unitized Wheels

Size	Wheels/Case	Max. Oper. RPMs	Mineral Type/Grade UPC (048011-)					
			8 A CRS	8 A MED	6 A MED	6 S FIN	2 A MED	2 S FIN
2" dia.	60	22,100	17194	17192	17190	17187	17185	17183
3" dia.	40	15,100	17195	17193	17191	17189	17186	17184

## Ordering Information for Roloc™ Coating Removal Discs

Product Number	UPC (051144-)	Description	Size	Inner Unit Pack	Case Qty.
CR-DR	18364	CR-DR Roloc Coating RMVL DISC	S XCS 2XNH	60/disc	60
CR-DR	18350	CR-DR Roloc Coating RMVL DISC	S XCS 3XNH	40/disc	40
CR-DR	18470	CR-DR Roloc Coating RMVL DISC	S XCS 4XNH	40/disc	40

## Ordering Information for Roloc + Holders &amp; Button Combination Packs

Product	Use With	Sets/Case	UPC (048011-)
No. 1 and No. 7	Unitized Wheels 3" Diameter and smaller x 1/4" wide x 3/4" CH	5	14915
No. 1 and No. 6	Unitized Wheels 3" Diameter and smaller x 1/8" wide x 3/8" CH	5	14916

## Ordering Information for Introductory Packs

Prod. I.D.	Contents	Packs/Case	UPC (048011-)
992S	EXL Unitized Wheels 4 ea. 6A MED 1/2" x 1/8" x 1/8", 4 ea. 8A CRS 1/2" x 1/8" x 1/8", 2 ea. 2S FIN 1" x 1/4" x 1/8", 2 ea. 6A MED 1" x 1/8" x 1/8", 2 ea. 8A CRS 1" x 1/8" x 1/8", 2 ea. 2S FIN 1 1/2" x 1/4" x 3/16", 2 ea. 6A MED 1 1/2" x 1/8" x 3/16", 2 ea. 8A CRS 1 1/2" x 1/8" x 3/16", 2 ea. 2S FIN 2" x 1/4" x 3/16", 2 ea. 6A MED 2" x 1/8" x 3/16", 2 ea. 8A CRS 2" x 1/8" x 3/16" Mandrels 1 ea. 992 with short cap, 1 ea. 994 with short cap, 1 ea. 996, 1 ea. 998	5	15509
988S	EXL Roloc Unitized Wheel - 3" Dia. 1 ea. 2S FIN, 1 ea. 2A MED, 1 ea. 6S FIN, 1 ea. 6A MED, 1 ea. 8A MED, 1 ea. 8A CRS, Roloc+ Holder 1 ea. No. 1	5	17182



# Stikit™ Disc Rolls and Accessories



188

## 3M™ Stikit Disc Rolls

- Pressure-sensitive adhesive for press-on, peel-off convenience
- Eliminates slippage between sander back-up pad and abrasive
- Discs resist loading and reduce “down time”
- For use on paint, primer, wood, metal and fiberglass
- General use 5" Discs

## 3M Stikit Disc Pads

- Lightweight and shock-resistant
- Tough vinyl face provides excellent disc adhesion yet allows quick, easy disc removal
- Designed for use of dual action and random orbital sanders

## Ordering Information for Stikit Discs

Product Number	UPC (051144-)	Description	Size	Inner Unit Pack	Case Qty.
316U	01237*	80D 3M Stikit Disc Roll	5XNH	100/roll	6
316U	01235	P120 3M Stikit Disc Roll	5XNH	100/roll	6
240N	01515	36D 3M240N STIK PROD DISCS	5"	1/box	5
240N	01514	40D 3M240N STIK PROD DISCS	5"	1/box	5
255L	01381	P120 3M255L STIK GOLD FILM DF	6XNH 125/RL	1/box	4
414N	01454	180A 3M414N STIK TRI FC PA OP DR	5XNH	1/box	4

\* UPC prefix 051131-

## Ordering Information for 3M 415U/415N Stikit Tri-M-ite™ Silicon Carbide Refill Rolls

Size	Prod. I.D.	Min./Unit	Pkg. 80A	Grade and UPC (051144-)							
				100A	120A	150A	180A	220A	240A	280A	320A
2 1/2" wide	415U	10/50	14475	16287	16286	16285	16284	16283	-	-	-
3 1/4" wide	415U/415N	10/50	14476	16295	16294	16293	16292	16291	-	16289	16288**

\*\* 415N

## Ordering Information for Stikit Disc Pads

Diameter	Thickness	Thread	Face Color	Case Qty.	Max. RPM	UPC (051144-)
5"	3/4"	5/16"-24 external	Blue	10	10,000	05575
5"	3/4"	5/16"-24 external	Silver	10	10,000	45215
5"	3/4"	5/16"-24 external	Red	10	10,000	81821
5"	3/4"	5/16"-24 external (soft)	Blue	10	R/O only	83211
5"	3/4"	5/8"-11 internal	Red	10	10,000	82189
5"	11/16"	5/8"-11 internal	Red	1	9,000	82655
6"	3/4"	5/16"-24 external	Blue	10	10,000	05576
6"	3/4"	5/16"-24 external	Silver	10	10,000	45216

## Ordering Information for Sanding Blocks

Product Number	UPC (051144-)	Description	Size	Inner Unit Pack	Case Qty
<b>Stikit Sanding Blocks</b>					
45203	45203	Stikit Sanding Block	2-1/2"	10 pack	10
45204	45204	Stikit Sanding Block	3-1/4"	10 pack	10



189

### 3M™ PSA Production™ Discs

- Pressure-sensitive adhesive for press-on, peel-off convenience
- Eliminates slippage between sander back-up pad and abrasive
- Discs resist loading and reduce “down time”
- For use on paint, primer, wood, metal and fiberglass

### Ordering Information for 3M Three-M-ite™ Resin Bond PSA

Size	I.D.	Prod. Min.Pkg./ Case	Grade and UPC (051144-)											
			24	36	40	50	60	80	100	120	150	180	240	320
1/2"	248D	50/500		97632*	97633*	97634	20951	20950	20949	20948	97635*	97636*	97637*	97638*
3/4"	248D	50/500		97639*	97640*	97641*	20943	20942	20941	20940	97642*	20939	20938*	97643*
1"	248D	50/500			97644*	20934	20933	20932	20931	20930		20928	20927	97645*
1 1/2"	248D	50/500			97646*	20923*	20922	20921	20920	20919	97647	20917	20916	97648*
2"	248D	50/200		20913	20912	20911	20910	20909	20908	20907	20906	20905	20903	
2"	218K	50/200												20732
3"	248D	50/200	01383	01337	01335	01334	01333	01332	01331	01330	01329	01328	01326	01306
4"	248D	50/200		20900	21499*	20899	20898	20897	20896	97649*	97650*	97651*	97652*	97653*
5"	248D	50/250		20891	20890	20889	20888	20887	20886	20885	20884	20883	20881	97654*
6"	248D	50/250		21639	21731	20879	20878	20877	20876	21497	97655*	21496	97656*	
8"	248D	50/250		20874	20873	20872*	20871	20870	20869	20868			20867*	
9"	248D	50/250		97657*	97658*	97659*	20866	20865	97660*	97661*				
10"	248D	10		49536	49537	49538*	49689	49688	49539	49540*				
12"	248D	10		88906	88905	88904	88903	88902	88901		88900*	88899		
15"	248D	10		88895	88894	88893	88892	88891	49692*					
16"	248D	10		88890	88889	88888	88887	88886						
18"	248D	10		88882	88881	49691*	88880	88879						
20"	248D	10		88878	88877	88876	88875	88874	49690*					
24"	248D	10		20802	20801	20800*	20799	20798	97665*					
30"	248D	10		20793	20792	97666*	20791*	97668*						

Add prefix 051111- to UPC No. when ordering 10" sizes.

\*Kut stock items

### Ordering Information for PSA Discs Rolls

Product Number	UPC (051144-)	Description	Size	Inner Unit Pack	Case Qty
<b>3M PSA Production Discs (Disc Rolls)</b>					
316U	01236	100 3M316U PSA D/R	5XNH	1/rls	6
316U	01234	150 3M316U PSA D/R	5XNH	1/rls	6
316U	01232	220 3M316U PSA D/R	5XNH	1/rls	6
316U	01229	320 3M316U PSA D/R	5XNH	1/rls	6
316U	01227	400 3M316U PSA D/R	5XNH	1/rls	6

## Ordering Information for 3M™ PSA Disc Holders

<b>Diameter and Shank</b>	<b>Max. RPMs</b>	<b>UPC (051144-)</b>
1/2" x 1/4"	20,000	45074
3/4" x 1/4"	20,000	45073
1" x 1/4"	20,000	45072
2" x 1/4"	15,000	45070
3" x 1/4"	10,000	05510
4" x 1/4"	7,500	45069
5" x 1/4"	6,000	45068

# Surface Conditioning Discs and Accessories

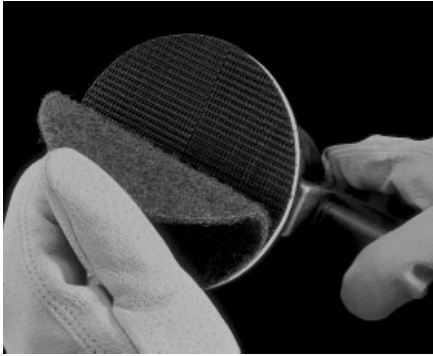

190



191

## 3M™ Surface Conditioning Discs (Hook and Loop)

- Used for heavy deburring, cleaning and finishing applications
- Scotch-Brite™ “SE” surface conditioning products feature a coarser, tougher, more aggressive, abrasive impregnated web construction than regular Scotch-Brite surface conditioning products

## Ordering Information for Surface Conditioning Discs (Hook and Loop)

Size	Discs/Case	Mineral Type/Grade UPC (048011-)			
		A CRS	A MED	A VFN	S SFN
2" x NH	200	07458	07459	04276	04127
3" x NH	100	04120	04124	04277	04128
4" x NH	100	07450	07451	04278	04129
4 1/2" x NH	50	14101	14100	14099	14102
5" x NH	50	00750	00643	04303	00647
5" x 7/8"	50	16047	00644	-	-
7" x NH	25	00751	00645	04305	00648
<b>SE Surface Conditioning Discs (Hook and Loop)</b>					
2" x NH	200	-	18473	-	-
3" x NH	100	-	18474	-	-
4" x NH	100	18021	18475	-	-
4 1/2" x NH	50	18079	18476	-	-
5" x NH	50	18080	18919	-	-
7" x NH	25	17866	18477	-	-

## Ordering Information for Surface Conditioning Accessories

Prod. No.	UPC (051144-)	Description	Inner Size	Unit Pack	Case Qty
<b>Surface Conditioning Disc Pad Holders (Hook and Loop)</b>					
922	07494	DH-AC 3M BR SURF COND DC HLDR 922	2"	10/each	10
923	04132	DH-AC 3M BR SURF COND DC HLDR 923	3"	10/each	10
924	07492	DH-AC 3M BR SURF COND DC HLDR 924	4"	5/each	5
914	05674	DH-AC 3M Brand Disc Pad Holder 914	4 5/8-11	1/each	1
914	05673	DH-AC 3M BR SURF COND DC HLDR 914	4 1/2-13	1/each	1
9145	14111	DH-AC 3M Brand Disc Pad Holder 9145	4 5/8 -11	1/each	1
915	05679	DH-AC 3M BR SURF COND DC HLDR 915	5"	1/each	1
915	05680	DH-AC 3M Brand Disc Pad Holder 915	5 5/8-11	1/each	1
917	04950	DH-AC 3M Brand Disc Pad Holder 917	7"	1/each	1

## Ordering Information for 9145S and 917S Introductory Packs

Prod. I.D.	Contents	Packs/Case	UPC (051144-)
9145S	Surface Conditioning Disc - 4 1/2" Dia. 1 ea. S SFN (Gray), 1 ea. A VFN (Blue), 1 ea. A MED (Maroon), 1 ea. A CRS (Brown) Disc Pad Holder (Hook and Loop) 1 ea. 9145 5/8" -11	5	14105
917S	Surface Conditioning Disc - 7" Dia. 1 ea. S SFN (Gray), 1 ea. A VFN (Blue), 1 ea. A MED (Maroon), 1 ea. A CRS (Brown) Disc Pad Holder (Hook and Loop) 1 ea. 917 5/8" -11	5	04270



192

### 3M™ Coating Removal Discs (Hook and Loop)

- Rugged open web on disc is virtually non-loading
- Sand blast-like finish without the mess
- Aggressively tackles toughest cleaning jobs

### 3M Scotch-Brite™ Clean and Strip Discs

- Rugged open web design
- Virtually non-loading
- Cleans rust and coatings quickly
- Tackles your toughest cleaning jobs



3M Mandrel 933

193

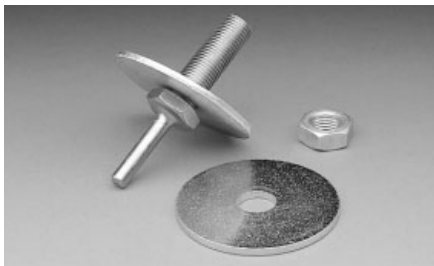

3M Mandrel 934

194

## Ordering Information for Coating Removal Discs (Hook and Loop)

Size	Discs/Case	Mineral Type/Grade	UPC (048011-) SXCS
4" x NH	40		18481
4 1/2" x NH	40		18482
5" x NH	40		18483
7" x NH	20		18485

**Recommended Operating RPMs:**

4" dia. - 5,000-8,000	5" dia. - 4,200-6,300
4 1/2" dia. - 4,700-7,000	7" dia. - 3,000-4,500

## Ordering Information for Clean and Strip Discs

Size	Discs/Case	Max. Oper. RPMs	Mineral Type/Grade	UPC (048011-) SXCS
2 x 1/4"	100	12,000		00931
3 x 1/4"	50	8,500		00935
3 x 1/2"	50	8,500		00937
4 x 1/4"	25	6,000		07460
4 x 3/8"	25	6,000		00940
4 x 1/2"	25	6,000		00941
4 x 5/8"	25	6,000		00942
5 x 1/2"	25	5,000		00943
6 x 1/4"	15	4,000		00946
6 x 3/8"	15	4,000		00947
6 x 1/2"	15	4,000		00948
6 x 5/8"	15	4,000		00949
6 x 7/8"	15	4,000		00950
7 x 5/8"	15	3,500		00954
7 x 7/8"	15	3,500		00955
8 x 1/2"	15	3,000		00957
8 x 5/8"	15	3,000		00958

## Ordering Information for 3M Mandrels

Prod.	Use With	Size	Per Case	UPC (048011-)
933	2"-3" dia. discs	2" lg x 1/4" shank 1" washer	5	13968
934	3"-6" dia. discs	3 1/16" lg x 1/4" shank 2 1/2" washer	1	04021

**Maximum Operating RPMs:**

933	—	14,000		
934	w/3" wheel	12,000		
	w/4" wheel	8,500		
	w/6" wheel	6,000		

The lower of the disc or mandrel MOS must always be used.



# Abrasive Belts

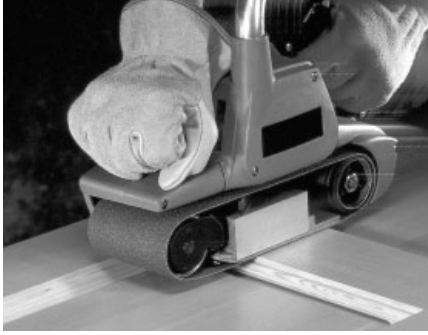

195

### 3M™ Abrasive Belts

- Small belts from 3" x 18" to 6" x 48"
- Ideal for everything from metalworking to woodworking

### 3M Regalite™ Belts

- Superb performance and long life
- Grinds cool with a high cut rate
- Grinding aids to provide optimum performance
- Combination of Cubitron™ mineral and aluminum oxide

### 3M Three-M-ite™ Cloth Belts

- Ideal for everything from metalworking to woodworking
- Aluminum Oxide

## Ordering Information for 3M 241D Three-M-ite RB Cloth x Wt.

Size	Prod. I.D.	Min. Pkg./Case	Grade and UPC (891040-)											
			24	36	40	50	60	80	100	120	150	180	220	240
3" x 21"	241D	10/40	02679	01422	01423	01424	01425	01426	01427	01428	01528	01529	02689	-
3" x 24"	241D	10/40	02681	01429	01430	01431	01432	01433	01434	01435	01536	-	-	02659
4" x 24"	241D	10/40	-	01436	01437	01438	01439	01440	01441	01442	-	-	-	-
6" x 48"	241D	10/40	-	01454	-	01456	-	01458	01459	01460	-	-	-	-

## Ordering Information for 3M 741E, 751E Regalite Resin Bond Cloth XE Wt., 3M™ 777F Regalite Polycut™ Resin Bond Cloth YF Wt.

Size	Prod. I.D.	Min. Pkg./Case	Grade and UPC (051144-)							
			36	40	50	60	80	100	P120	
1/4" x 24"	741E/751E	50/200	-	-	-	#13280	-	-	-	
1/2" x 12"	741E	50/200	-	-	-	#13276	-	-	-	
1/2" x 18"	777F	50/200	-	-	-	#80551	#80232	-	-	
	741E	50/200	-	-	-	#13733	-	-	-	
1/2" x 24"	777F	50/200	#77643	82342	#77408	#77065	#77491	-	#81064	
	741E/751E	50/200	-	-	-	#13272	-	-	-	
3/4" x 20 1/2"	741E	50/200	-	-	-	#13268	-	-	-	
1" x 30"	777F	50/200	#82252	-	-	-	#77407	-	-	
1" x 42"	777F	50/200	-	#76527	-	#77512	-	-	-	
6" x 48"	777F	20/20	-	-	-	76679	-	-	-	

## Ordering Information for 3M 240D/241D Three-M-ite Resin Bond Cloth Open Coat X Wt.

Size	Prod. I.D.	Min. Pkg./Case	Grade and UPC (051144-)											
			36	40	50	60	80	100	120	150	180	220	240	320
1/8" x 24"	241E	50/200	-	-	-	#71053	-	-	-	-	-	-	-	-
1/4" x 24"	241E/251E	50/200	-	#30290	-	#26733	#26732	#32407	#26731	-	#26730	-	-	#26729
1/2" x 12"	241E/251E	50/200	-	#32417	#26895	#31170	#26894	#26893	#26892	-	#31074	-	#32398	-
1" x 12"	241D	50/200	-	-	-	26884	26881	-	-	-	-	-	-	-
1/2" x 18"	241E/251E	50/200	#77632	#72226	-	#72227	#72228	#14754	#72229	-	-	-	-	-
1/2" x 24"	241E/251E	50/200	#32375	#26726	#26725	#26723	#26720	#26719	#26717	#26716	#26715	#26714	#32399	#26713
1/2" x 42"	241E	50/200	-	-	-	-	#34176	-	-	-	-	-	-	-
3/4" x 20 1/2"	241E/251E	50/200	#26784	#26783	#26782	#26781	#26780	#26779	#26778	-	#26776	-	-	-
1" x 30"	241E/251E	50/200	#32161	-	-	#33911	#33912	#32157	#32158	-	#32160	-	-	-
1" x 42"	241E	50/200	-	-	-	-	-	-	-	-	-	-	-	-
	241D	50/200	#26614	#26612	#31823	#26609	#31774	#26606	#33795	#26602	#26601	#26600	#26599	#26597
	240D	-	-	-	-	-	-	-	-	-	-	-	-	-
1 1/2" x 18 15/16"	241D	10/50	26822	-	26820	26819	26818	-	26816	-	26814	-	-	-

#Filmlok, #Fabriloc, \*Kut stock items

# Surface Conditioning Belts

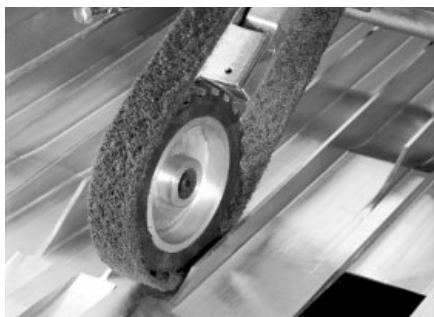

## 3M Scotch-Brite™ Surface Conditioning Belts

- Used worldwide to finish, polish and buff metal, wood and plastic surfaces

196

## Ordering Information for Surface Conditioning Belts

Size	Belts/Case	Mineral Type/Grade UPC (048011-)					T
		A CRS	A MED	A VFN	S SFN		
1/4" x 18"	20	13290	14276	-	-	-	
1/4" x 24"	20	13132	13131	13287	-	-	
1/2" x 12"	20	-	17515	19688	-	-	
1/2" x 18"	20	08858	08857	08856	08855	-	
1/2" x 24"	20	05741	03998	04299	17516	-	
3/4" x 18"	20	13639	15899	14543	15898	-	
1" x 18"	10	14278	14398	17517	-	-	
1" x 30"	10	08887	08898	08920	-	-	
1" x 42"	10	-	04189	04190	-	-	
2" x 1815/16"	10	08889	-	-	-	-	
2" x 34"	10	-	08905	-	-	-	
2" x 48"	10	-	08915	04295	-	-	
2" x 60"	10	05020	08916	08922	-	-	
2" x 72"	10	-	00580	00579	-	-	
2" x 132"	5	05021	03999	04297	-	-	
2 1/2" x 60"	10	-	00581	-	-	-	
2 3/4" x 15 1/2"	10	05022	05227	-	-	-	
3" x 10 11/16"	10	05820	05783	09650	-	-	
3" x 18"	10	14284	14285	14550	-	-	
3" x 21"	10	-	08906	-	-	-	
3" x 24"	10	08880	00583	04298	-	-	
3" x 72"	10	-	14548	-	-	-	
3" x 132"	5	05023	00568	04289	08893	-	
3 1/2" x 15 1/2"	10	05016	05228	05643	05644	14121	
4" x 24"	10	-	00585	-	-	-	
4" x 90"	10	-	-	-	15879	-	
4" x 132"	5	05018	00570	04281	-	-	
4" x 168"	5	-	00589	-	-	-	
6" x 48"	5	05019	00590	04283	-	-	

## Ordering Information for Introductory Packs

Prod. I.D.	Contents	Packs/Case	UPC (051144-)
518S	777S Regalite Polycut RB Cloth Belts 1/2" x 18" 2 ea. 60YF, 2 ea. 80YF,	5	82897
241S	Three-M-ite RB Cloth Belt 1/2" x 18" 2 ea. 120XE Surface Conditioning Belts 1/2" x 18" 1 ea. A VFN, 1 ea. A MED, 1 ea. A CRS	-	-
524S	777S Regalite Polycut RB Cloth Belts 1/2" x 24" 2 ea. 60YF, 2 ea. 80YF, 2 ea. 120YF Surface Conditioning Belts 1/2" x 24" 1 ea. A VFN, 1 ea. A MED, 1 ea. A CRS	5	82898

# Wheels

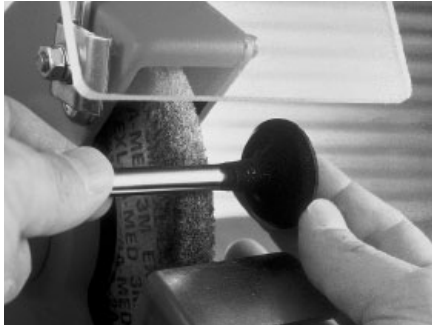

197

## 3M™ Scotch-Brite™ Wheels

- Safer than wire wheels
- Cleans more effectively
- Aggressive yet smooth running, less operator fatigue
- Cool operation prevents discoloration of parts
- Longer life

## 3M Scotch-Brite Bench Motor Wheel

- Cleans and deburrs metal surfaces and threads
- Eliminates danger of loose flying wires
- Polishes and finishes metals or composites
- Fits standard motor shaft sizes (1/2" to 1")

## Ordering Information for Scotch-Brite EXL Deburring Wheels

Size	Wheels/ Case	Max. Oper. RPMs	Density/Mineral Type/Grade/UPC (048011-)			
			8A MED	8S MED	8S FIN	9S FIN
6" x 1/2" x 1"	4	6,000	13616	18277	09548	05790
6" x 1" x 1"	3	6,000	13617	18278	09549	05132
6" x 1 1/2" x 1"	2	6,000	18186	-	-	-
6" x 2" x 1"	2	6,000	13618	-	-	05133
8" x 3/8" x 3"	4	4,500	-	-	14791	-
8" x 1/2" x 3"	4	4,500	17459	-	14629	05791
8" x 1" x 3"	3	4,500	13619	18279	09551	05135
8" x 2" x 3"	2	4,500	13620	-	09552	05136

## Ordering Information for Scotch-Brite EXL Unitized Deburring Wheels

Sz. Dia. x W x AH	No./ Case	2A MED (40811)	2S FIN (40811)	4A FIN (40811)	6A MED (40811)	6S FIN (40811)	8A MED (40811)	8A CRS (40811)
1" x 1" x 3/16"	50	-	-	-	-	15859 (35,100)	13753	-
3" x 1/4" x 1/4"	40	15531 (12,100)	13716 (12,100)	-	14067 (18,100)	-	13764 (18,100)	13763 (18,100)
6" x 1/2" x 1/2"	4	15534 (4,500)	13719 (5,000)	-	-	-	-	-
6" x 1/2" x 5/8"	4	-	15831(5,000)	-	-	-	-	-
6" x 1/2" x 1"	4	16545 (4,500)	14379 (5,000)	-	-	-	-	-
6" x 1" x 1"	2	16544 (4,500)	13743 (5,000)	-	-	-	13788 (7500)	-
8" x 1/2" x 1"	4	-	15823	-	-	-	-	-

## Ordering Information for Introductory Packs

Prod. I.D.	Contents	Packs/Case	UPC (048011-)
EXL	EXL Deburring Wheel 1 ea. 8A MED 6" x 1" x 1" EXL Unitized Wheel 1 ea. 2A MED 6" x 1/2" x 1" Flange Adaptor No. 5 1 ea. 1" x 1/2" x 1/2", 1 ea. 1" x 1" x 1/2"	5	16405

## Ordering Information for Wheels

Product Number	UPC (051144-)	Description	Inner Unit Pack	Case Qty.
<b>Scotch-Brite Bench Motor Wheel</b>				
IP-IP	07744	IP-IP S/B Bench Motor Wheel	5 each	5

### 3M™ Scotch-Brite™ Clean and Strip Cup Wheels

- Aggressive and long lasting
- Fits right angle grinders with 5/8"-11 thread
- Good for heavy cleaning and coating removal

#### Ordering Information for Clean and Strip Cup Wheel

Size Dia. x Thd.	Wheels/Case	Max. Oper. RPMs	Mineral Type/Grade UPS (048011-) S XCS
3" x 3/8 - 24	5	18,100	04151
4" x 3/8 - 24	4	12,100	04217
4" x 1/2 - 13	4	12,100	04152
4" x 5/8 - 11	4	12,100	04153
4" x M10 - 1.25	4	12,100	05519
4" x M10 - 1.5	4	12,100	04218
4" x M14	4	12,100	04154
6" x 7/8 *	2	7,000	04237

\* Accessories: Use 6" diameter cup wheel with the 3M Flap Disk Holder Kit, T27, UPC 051144-88769-9.  
The lower of the wheel or holder MOS rating must always be used.

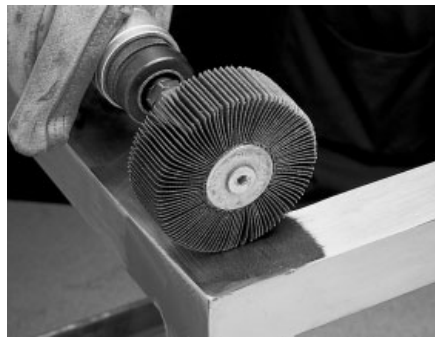

198

#### 3M™ Flap Wheels

- As they wear, they continually expose new abrasive
- Premium aluminum oxide mineral and Cubitron™ ceramic aluminum oxide coated on a cloth backing
- 1/4" shaft unless noted

#### Ordering Information for 3M 747D Regalite™ Polycut™ Resin Bond Cloth x Wt. (Flap Wheels)

Sz. Dia. x W x Shk.	Prod. I.D.	Min. Pkg./Case	Max. Oper. RPMs	Grade and UPC (051144-)								
				40	60	80	100	120	150	180	240	320
<b>T83</b>												
1" x 1" x 1/4"	747D	10	25,000	-	80761	80757	-	80753	-	-	-	-
1 1/2" x 1" x 1/4"	747D	10	22,000	-	80762	80758	-	80754	-	-	-	-
2" x 1" x 1/4"	747D	10	20,000	-	80763	80759	-	80755	-	-	-	-
2 1/2" x 1" x 1/4"	747D	10	18,000	-	80764	80760	-	80756	-	-	-	-
3" x 1" x 1/4"	747D	10	18,000	-	80650	80651	-	80652	-	-	-	-

#### Ordering Information for 3M 741A Regalite RB Cloth X Wt. & 3M™ 244E Three-M-ite™ RB Cloth XE Wt. (Flap Wheels)

Sz. Dia. x W x AH	Prod. I.D.	Min. Pkg./Case	Max. Oper. RPMs	Grade and UPC No.* (051144-)							
				40	50	60	80	100	120	150	
6" x 1" x 1"	741A	1/5	6,100	-	82770	81986	81984	-	-	-	-
6" x 1 1/2" x 1"	741A/244E	1/5	5,600	-	-	81987	81985/35098	-	81982	-	-
6" x 2" x 1"	741A	1/5	5,200	-	-	81988	81989	-	81983	-	-





### 3M™ Cut-Off Wheels

- General purpose abrasive wheels
- Used for cutting sheet metal, rusted bolts and more
- Do not use without guards

### 3M Green Corps™ Cut-Off Wheels – Premium

- Extra high cut rates and long life
- Provides top level grinding for fiberglass, stainless steel, mild steel and alloys
- Do not use without guards

199

## Ordering Information for Green Corps Cut-Off Wheels

Size	Pkg. Min./Unit	Max. RPMs	UPC (051144-)
2" x 1/16" x 1/4"	bulk, 50 wheels/box	42,000	83487
3" x 1/32" x 1/4"	bulk, 50 wheels/box	35,000	82238
3" x 1/32" x 3/8"	1/pack, 10/case	35,000	01989
3" x 1/16" x 3/8"	1/pack, 10/case	28,000	01990
4" x 1/32" x 3/8"	bulk, 50 wheels/box	26,250	01994
4" x 1/16" x 3/8"	bulk, 50 wheels/box	21,000	83488

## Ordering Information for 3M Green Corps Reinforced Weld Grinding Wheel

Size	Pkg. Min./Unit	Max. RPMs	UPC (051131-)
3" x 3/16" x 3/8"	5 pack/5 packs case	20,375	01991

## Ordering Information for General Purpose Cut-Off Wheels

Size	Pkg. Min./Unit	Max. RPMs	UPC (051131-)
3" x 1/32" x 3/8"	50 wheels per case	25,000	01987
3" x 1/16" x 3/8"	50 wheels per case	25,000	01988

## Ordering Information for Metal Finishing Wheel

Size	Pkg. Min/Unit	Description	UPC (048011-)
8" x 2" x 3"	2 wheels/case	5A MED	01876

# Bench Area Products

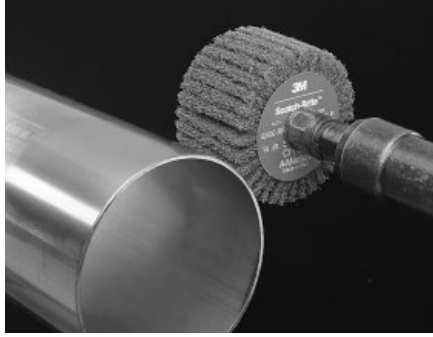

200

## 3M™ Bench Area Products

- Scotch-Brite™ high performance web made into a flap brush
- Outlasts conventional webs
- 1/4" shaft unless noted

## 3M Combi Wheels

- Combination of aluminum oxide coated abrasive and Scotch-Brite™ material
- 1/4" shaft

## 3M Cartridge Rolls

- Premium constructed cartridge rolls
- Cubitron™ and aluminum oxide minerals coated on an X-wt backing
- 1/8" Center Hole unless noted

## 3M Bench Area Products

### Ordering Information for CPFB-R, CPFB-S

Size	Prod. I.D.	Discs/Unit	Max. Oper. RPMs	Mineral Type/Grade UPC (048011-)	
				A	MED
2" x 1" x 1/4"	CPFBS	25	12,000	16622	
3" x 1 3/8"	CPFBR	10	8,000	14588	
2" x 1 3/4" x 1/4"	CPFBS	10	8,500	05974	

### Ordering Information for CPFF-R, CFFB-S

Size	Prod. I.D.	Brushes/Case	Max. Oper. RPMs	Mineral Type/Grade UPC (048011-)	
				A CRS	S SFN
3" x 1 3/8"	CFFBR	10	7,500	14587	14783
3" x 1 3/4" x 1/4"	CFFBS	10	8,500	05975	14781

### Ordering Information for 3M COMBI Wheels

Size	Prod. I.D.	Wheels/Case	80X	Grade UPC (048011-)	
				P120X	P180X
3" x 1 3/4" x 1/4"	COMBIS	10	80801	80678	-

### Ordering Information for 3M Cartridge Rolls

Sz. Dia x W x AH	Prod. I.D.	Min.Pkg./Case	Grade and UPC (051144-)										
			36	40	50	60	80	100	120	150	180	240	320
3/8" x 1" x 1/8"	241D	50/200	-	-	97238	97239	97240	97241	97242	97243	97244	97245	97246
1" x 2" x 3/16"	241D	50/200	97228	97229	97230	97231	97232	97233	97234	-	97235	97236	97237

### Ordering Information for Accessories

Product Number	UPC (051144-)	Description	Size	Inner Unit Pack	Case Qty
<b>3M Cartridge Rolls- Accessories</b>					
45121	45121	Spindle	1/4" Dia, 1/4" Shank	1 each	1
<b>3M Square Pads</b>					
241D	97709	80X 3M241D THREE-M-ITE™ RB CLO SQ	2" x 2" x 1/2"	50/pads	100

# Diamond Grade Products

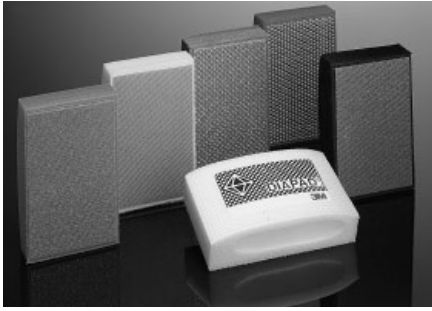

201

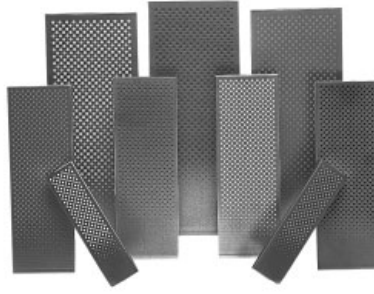

202

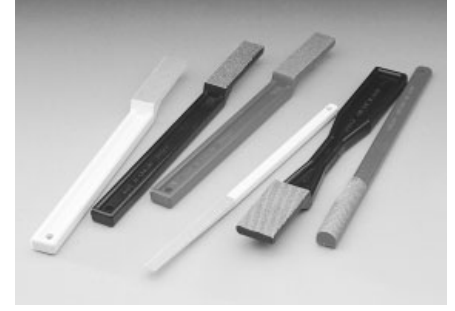

203

## Ordering Information for 3M™ 6200J Hand Pads

Size	Pads/Case	Micron Grade and UPC No. (051144)							
		M250	M125	M74	M40	M20	M10	R30	R10
2 1/4" x 3 3/4"	10	14998	14999	80098	80099	80100	81895	80101	80102
2 1/4" x 4"	10	14983	14984	14985	14986	14987		14988	14989
3" x 3"	10	14976	14977	14978	14979	14980		14981	14982

## Ordering Information for 3M 6223J Professional Diamond Whetstone

Size	Items/Case	Micron Grade and UPC No. (051144)		
		M74	M40	M20
1" x 4" (DW61)	5	85921	85922	85923
2" x 6" (DW42)	5	85924	85907	85908

## Ordering Information for 3M Diamond Files

Size	Micron Grade and UPC No. (051144)			
	M125 (Black)	M74 (Red)	M40 (Yellow)	M20 (White)
1 1/2" x 3/4"	80829	80830	80831	80832
1 3/4" x 1/2"	80833	80834	80835	80836
1 3/4" x 1/2" half round	80837	80838	80839	80840
2 1/2" x 1/4"	80841	80842	80843	80844
<b>Sets</b>				
Assorted	80130	80131	80132	80133

## Retail Packs

## Ordering Information for Retail Packs

Product No.	UPC (051144-)	Description	Size	Inner Unit	Case Pack Qty
<b>3M™ Auto-Pak™ Imperial™ Wetordry™ Sandpapers</b>					
03001NA	03001*	Levels Paint Defects	3-2/3" x 9"	40/pack	40
03002NA	03002*	Final Sanding	3-2/3" x 9"	40/pack	40
03003NA	03003*	For Premier Finish	3-2/3" x 9"	40/pack	40
03004NA	03004	Fine	9" x 11"	40/pack	40
03005NA	03005	Medium	9" x 11"	40/pack	40
03007NA	03007	Coarse	9" x 11"	40/pack	40
<b>3M Auto-Pak</b>					
03008	03008*	Emery Cloth Sheets Assorted	3-2/3" x 9"	40/pack	40
03009NA	03009*	Aluminum Oxide Sandpaper Assorted	9" x 11"	40/pack	40
03010NA	03010	Emery Cloth Sheets Assorted	9" x 11"	20/pack	20
03013NA	03013	Wetordry Sandpaper U. Fine (600A)	9" x 11"	40/pack	40
03015NA	03015	Wetordry Sandpaper S. Fine (400A)	9" x 11"	40/pack	40
03016NA	03016*	Imperial Wetordry Sandpapers (Primer Coat)	3-2/3" x 9"	40/pack	40
03017NA	03017	Wetordry Sandpaper E. Fine (320A)	9" x 11"	40/pack	40
03018NA	03018	Imperial Wetordry Sandpapers (Sanding Putty/Primers)	3-2/3" x 9"	40/pack	40
03019NA	03019	Wetordry Sandpaper V. Fine (600A)	9" x 11"	40/pack	40
03020NA	03020*	Imperial Wetordry Sandpapers (Final Primer Sanding)	3-2/3" x 9"	40/pack	40
03021NA	03021	Wetordry Sandpaper Assorted	9" x 11"	40/pack	40
03022NA	03022*	Imperial Wetordry Sandpapers (Removes Paint Defects)	3-2/3" x 9"	40/pack	40
03024NA	03024*	Imperial Wetordry Sandpapers (Assorted)	3-2/3" x 9"	40/pack	40
03026NA	03026	Quarter Sheet Assortment Aluminum Oxide	4.5" x 5.5"	50/pack	50
03027NA	03027*	Quarter Sheet Abrasive Assortment Packs Emery Cloth	4.5" x 5.5"	50/pack	50
03031NA	03031	Aluminum Oxide Sandpaper Fine	3-2/3" x 9"	40/pack	40
03035NA	03035	Aluminum Oxide Sandpaper Medium	3-2/3" x 9"	40/pack	40
03038NA	03038	Aluminum Oxide Sandpaper Course	3-2/3" x 9"	40/pack	40
03039NA	03039*	Aluminum Oxide Sandpaper Assorted	3-2/3" x 9"	40/pack	40
<b>3M Drill Mounted</b>					
03050NA	03050*	Grinding/Sanding/Finishing System Finishing Kit	6/each —	6	
03051NA	03051	Grinding/Sanding/Finishing System	2" Disc Holder	10/each	10
03054NA	03054*	Grinding/Sanding/Finishing Discs Coarse 36 Grit	10/pack —	10	
03058NA	03058*	Grinding/Sanding/Finishing Discs Coarse Assorted	20/pack —	20	
03059NA	03059*	Grinding/Sanding/Finishing Discs Assorted	—	20/pack	20

Continued on next page.

\*UPC prefix 051131-

## Ordering Information for Retail Packs

Product Number	UPC (051144-)	Description	Size	Inner Unit Pack	Case Qty
<b>3M™ Auto-Pak™ Sandpaper Discs</b>					
03105	03105	Discs Assorted 5" Diameter	—	40/pack	40
<b>3M™ Regalite™</b>					
03106NA	03106*	Regalite Fibre Grinding Discs 80 Grit	5" x 7/8"	20/pack	20
03107NA	03107*	Regalite Fibre Grinding Discs 36 Grit	5" x 7/8"	20/pack	20
03108NA	03108*	Regalite Fibre Grinding Discs 80 Grit	7" x 7/8"	20/pack	20
03109NA	03109*	Regalite Fibre Grinding Discs 36 Grit	7" x 7/8"	20/pack	20
03134NA	03025*	Quarter Sheet Assortment Silicon Carbide Wetordry	—	pack	50
03171NA	03171*	Rust & Paint Stripper	—	each	24
03172NA	03172*	3M Heavy Duty Rust & Paint Stripper	4" Diameter	each	24
03173NA	03173*	3M Auto-Pak Light Rust and Paint Remover	—	each	24
<b>3M™ Adhesive Packed</b>					
03110NA	03110	Adhesive Backed Sanding Discs /Fine	5" Diameter	40/pack-	40
03111NA	03111	Adhesive Backed Sanding Discs/ Medium	5" Diameter	40/pack	40
03112NA	03112	Adhesive Backed Sanding Discs / Coarse	5" Diameter	40/pack	40
03113NA	03113*	Adhesive Backed Sanding Discs /Assorted	5" Diameter	40/pack	40
03114NA	03114*	Adhesive Backed Sanding Discs /Fine	6" Diameter	40/pack	40
03115NA	03115*	Adhesive Backed Sanding Discs /Medium	6" Diameter	40/pack	40
03116NA	03116*	Adhesive Backed Sanding Discs/Assorted	6" Diameter	40/pack	40
<b>3M™ Quick Change</b>					
03118	03118*	5" Quick-Change Sanding Discs and Pad	5" Disc Pad	10/each	10
03121NA	03121*	5" Quick-Change Sanding Discs and Pad 180/Fine	—	10/pack	40
03122NA	03122*	5" Quick-Change Sanding Discs and Pad 80/Medium	—	10/pack	40
03123NA	03123*	5" Quick-Change Sanding Discs and Pad 40/Coarse	—	10/pack	40
<b>3M™ Disc Pad</b>					
03140	03140	Disc Pad	—	pack	10
03142NA	03142	Press 'n Disc Pad	—	each	10
<b>3M™ Auto Pack Misc.</b>					
03130NA	03130	Abrasive Cloth Sanding Rolls Extra Fine	1" x 6'	10/rls	10
03131NA	03131	Abrasive Cloth Sanding Rolls Fine	1" x 6'	10/rls	10
03132NA	03132	Abrasive Cloth Sanding Rolls Medium	1" x 4 1/2'	10/rls	10
03148NA	03148	Rubber Sanding Block	—	each	4
03180NA	03180*	3M Rust Avenger Rust Converter	—	each	10
03192	03192	3M Auto-Pak Tack Cloth	16" x 20"	each	40
03193NA	03193*	3M Auto-Pak Paint & Body Scuff Pad	6" x 9"	each	20
03194NA	03194*	3M Auto-Pak Clear Coat Scuff Pad	6" x 9"	pack	20
03900	03900*	3M Rubbing Compound (Fine Cut)	—	each	6
03902	03902*	3M Body Repair Finish Restorer	—	each	6
03905NA	03905*	3M Polishing Pad Kit	—	each	24
05720	05720	3M Superbuff Buffing Pad	6"	each	12
09417NA	09417	3M Buffing Pad	—	each	10
09418NA	09418	3M Polishing Pad	5.25" Diameter	each	10

\*UPC prefix 051131-

