

Effective April 1, 2004
Catalog No. 89076-12



**High
Quality
Fasteners**



Fastener Technology
... Engineered Solutions

30/45°

Holo-Krome Continues Over Seven Decades of Excellence

The Holo-Krome Company has been a leader in the Socket Screw industry for over 70 years.

In 1930, we developed and later patented the first practical cold heading process for mass producing high tensile alloy steel socket screws.

Today, virtually all products of that nature are manufactured by one or more of the methods developed by Holo-Krome.

With only slight changes in shape or dimensions, we are able to head many parts that previously took a screw machine to produce — and are doing it at a significant savings.

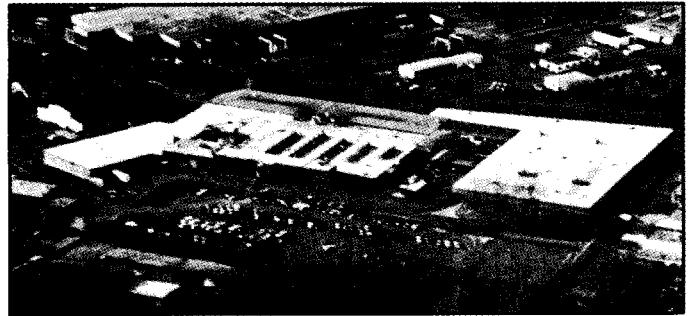

West Hartford, Connecticut



Unfailing Fasteners.

When fastener talk turns to quality, one brand is mentioned without fail: Holo-Krome. And little wonder, for Holo-Krome fasteners have been performing in some pretty tight spots, under tremendous pressures, for years, even decades, without fail. How? The answer is simple. There is no compromising when it comes to quality. None.

Benefit: Traceability. Each fastener has its own quality control number tracing it all the way back to the steel mill.

Benefit: SPC (Statistical Process Control). Today's term for the latest in quality control.

Benefit: The highest torque/clamping force available in the entire industry.

Benefit: Roll Threading, not thread cutting, for stronger, more precise radiused root and run-out threads for increased fatigue life.

Benefit: Technical support for those tough questions for design and applications engineers — over the phone or on-site.

Benefit: The most complete line of fasteners in the business in both inch and metric sizes.

Table of Contents

Inch Fasteners	Page	Semi-Standard Fasteners	Page
Socket Head Cap Screws-Coarse Thread	7-9	Socket Head Cap Screws - Coarse Thread	40
Socket Head Cap Screws-Fine Thread	10-11	Socket Head Cap Screws - Fine Thread	41
Stainless Steel Socket Head Cap Screws	12	Cap Screws Zinc Plated - Coarse Thread	42-44
Low Head Socket Cap Screws	13	Cap Screws Zinc Plated - Fine Thread	44-45
Flat Head Socket Cap Screws	13-14	Metric Cap Screws Zinc Plated	46-47
Button Head Cap Screws	15	Metric Skt Hd Cap-Stainless	47
Socket Set Screws-Cup Point	16-17	Set Screws, Cup Pt Stainless	48
Socket Set Screws-Holo-Knur [®] Point	18	Set Screws, Cup Pt Stainless w/Nylon Patch ..	48
Socket Set Screws-Cone Point	19-20	Metric Holo-Knur [®] Set Screws	49
Socket Set Screws-Flat Point	19-20	Set Screws, Half Dog	50
Socket Set Screws-Half Dog Point	19-20	Set Screws Half Dog w/Nylon Patch	50
Socket Set Screws-Oval Point	19-20		
Stainless Steel Socket Set Screws-Cup Point .	20	Allen Hex Keys and Sets	
Socket Jam Screws	21	Assortments Inch/Metric	51-52
Shoulder Screw	21-22	Dimension Standards Inch/Metric	53-54
Dowel Pins-Standard	23-24		
Dowel Pins-Oversize	24		
Pull Dowels	25		
Socket Pressure Plugs	26		
Allenuts	27-28		
Stainless Allenuts	28		
Metric Fasteners			
Metric Socket Head Cap Screws	29-32		
Blue Metric Cap Screws	32-34		
Metric Low Head Cap Screws	35		
Metric Socket Flat Head Cap Screws	36		
Metric Button Head Cap Screws	37		
Metric Socket Set Screws-Cup Point	38		



Customer Service
Danaher Tool Group
11011 McCormick Road
Hunt Valley, MD 21031
800-866-5753



INFORMATION AND TERMS

Product Code Number: All standard products have an assigned product code number shown on the boxes for ease in ordering and inventory control. All products are sold in *full packages only*.

Certifications: There is a lot number stamped on the outside of the box of every Holo-Krome socket screws. From this number, we can, when requested, certify the chemical analysis, the raw material supplier and the mechanical/dimensional properties of the product.

Product Plating & Modification: The Holo-Krome or Danaher Tool Group shall not be responsible for products plated or modified in any manner not under its control.

Prices: Prices are subject to change without notice.

Bulk Prices: Quantity pricing for bulk (non-package) available on request. Contact your nearest Holo-Krome distributor for details. For the name of the authorized Holo-Krome distributor nearest you, call toll free 1-800-866-5753.

Special Products: Products not listed in this schedule are special and will be quoted on request. Blueprints and specifications should accompany your request.

Shipments: We will attempt to ship in accordance with your instructions and by carrier of your choice. However, final selection of method of shipment and carrier will be at our sole discretion.

Product Catalog: This catalog has the most requested fasteners manufactured by Holo-Krome. If you have a need for an item not listed, please call our customer service department at 1-800-866-5753.

Limited Warranty and Exclusion Remedy

Products sold hereunder which are manufactured by Holo-Krome or Danaher Tool Group are warranted to conform to specifications of latest issue. This warranty is expressly in lieu of all other warranties whether expressed or implied, including without limitations any implied warranty of merchantability or fitness for a particular purpose.

Holo-Krome will repair or replace without charge to the buyer, except for the cost of shipping, products under warranty, which are returned to Holo-Krome's factory which Holo-Krome in its sole opinion finds were not manufactured in accordance with the warranty and have not been subjected to misuse or modified in any way.

This shall be the sole and exclusive remedy of the buyer under this warranty.

Disclaimer and Limitation of Liability

Liability on any claim of any kind, including negligence, for any loss or damage arising out of, connected with, or resulting from the performance or breach of the terms hereof, or from the design, manufacture, sale, delivery, resale, installation, technical direction, inspection, repair, or use of any product shall in no case exceed the price of the products which give rise to the claim. In no event, including the case of a claim for negligence, shall Danaher Tool Group have any liability for any incidental or consequential damage.

The World's Third Most Expensive Fastener.



The most expensive fastener anyone can buy is one that fails. The next most expensive fastener is one that saves a few pennies on price, then takes them all back by adding dollars to your in-place costs. Next comes Holo-Krome Thermo-Forged® precision fasteners with greater endurance and fatigue life. They do a better job than ordinary fasteners.

Because, unlike fasteners of unknown origin, ours come with more than 70 years of specialized engineering support; manufactured, tested and certified in our modern plant in West Hartford, Connecticut. For the name of the authorized Holo-Krome distributor nearest you, call toll-free 1-800-866-5753. Ask to see our Quality Fastener videos.

The most expensive fasteners.

The failures. Fasteners that fail to live up to the manufacturer's or importer's claims. Fasteners that save a few pennies initially, but end up costing hundreds, maybe even thousands of dollars in replacement costs. Fasteners of unknown origin that don't carry a manufacturing pedigree. Fasteners that can even cost you your priceless reputation. Fasteners without the unmistakable Holo-Krome brand.



Second most expensive fasteners.

But what they lack in strength, can usually be made up in numbers. So, drill more holes, use more and larger fasteners, and the chances are pretty good that everything will hold together. That is, everything but your budget. Here's why...

18/82

When determining total fastener cost, studies show that the per unit price of a given fastener represents only approximately 18% of its total in-place cost. The other 82% covers drilling, tapping, and assembly steps. The real money is saved by using fewer, stronger fasteners. Before you buy imported, or bargain priced fasteners, consider the overall cost figure, and discover where the real value lies.

Third most expensive fasteners.

- Thermo-forging produces maximum available strength.
- Precision 3A threads for greater clamping force.
- Radius root and radius run-out threads for structural integrity.
- Controlled fillets for uniform loading under the head.
- Technical support to assist in solving fastening problems.
- Factory training schools build technically competent Distributor Sales Staff.
- Value added services from over 300 distributors nationwide.
- Inspection at controlled intervals — Filing of test data for long term traceability, long term reliability.



When you consider the less expensive, higher risk alternative, Holo-Krome is the real value. Often the least expensive fastener.



Fasteners



Registered
to ISO 9001
Certification
No. A2680

Holo-Krome Can Make Your Tough Shapes Easier

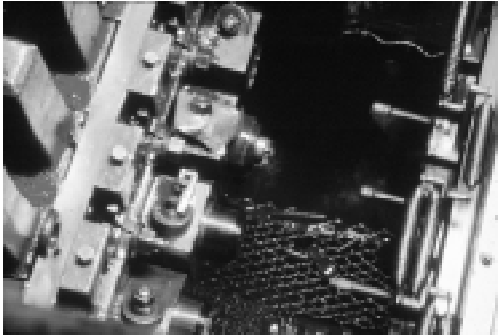

Manufacturing parts with unusual contour, strength and cost requirements often becomes uneconomical as material, labor and energy costs escalate.

For many companies, Holo-Krome has become the economic design and manufacturing alternative. The key is metal forming versus metal removal. We have 70 plus years of experience of applied technology in forming metal solutions. For us, tough parts take shape just a little easier.

FASTER.

Close tolerance, dimensionally complete parts roll off our headers at high production rates. To provide maximum economic benefit, the heading process requires larger production runs, generally exceeding 25,000 pieces.

STRONGER.

Shaping metal by controlled cold or warm forming yields inherently stronger parts. Through a stepped series of extrusion/heading "blows," Holo-Krome can shape even stubborn stainless alloys into difficult dimensions, while retaining the important metallurgical property of material grain flow. For many parts, tensile and shear strength properties are actually improved.

In contrast, machining parts to achieve similar dimensions often reduces the structural integrity of the finished part.

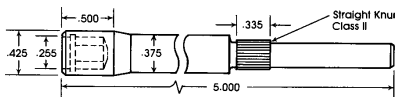

RIGHT DOWN TO THE FINISH.

Our vertically integrated manufacturing process encompasses many secondary and finish operations common to industry, they include:

- High speed/proprietary trimming
- Full capability contour grinding
- Precision roll threading up to 1-3/4" diameter
- Controlled atmosphere heat treatment
- Complete range of coatings and platings. The fact is, the surface quality of a formed part often eliminates the need for costly cosmetic rework.

AT LESS COST.

If your expensive, tough-to-manufacture shapes qualify for heading, the results can be astonishing and rewarding. The savings in material alone normally justifies switching to a Holo-Krome formed part with savings in labor, energy and reclamation costs.



With technology to engineer the solution, capacity to service the globe, why not let us solve your next "tough shape" problem. Contact our tough shapes specialists. We'll respond to your inquiry, fast.

Holo-Krome Company
West Hartford, CT 06110
Fax (860) 523-3480

Web Page: www.holokrome.com

Customer Service
Danaher Tool Group
11011 McCormick Road
Hunt Valley, MD 21031
800-866-5753

ENGINEERING SOLUTIONS IN STEEL.



Socket Head Cap Screws

UNRC COARSE THREAD SERIES • 1960 SERIES
 HEAT TREATED ALLOY STEEL • UNIFIED 3A THREAD FIT
 MEETS ASME/ANSI B18.3

DIAMETER	LENGTH UNDER HEAD	THREAD SERIES UNRC	PRODUCT CODE NUMBER	APPROX. WT. LBS. PER BOX	QTY IN BOX
#2 (.086") 5/64" Key	3/16"	56	72002	.1	100
	1/4"	56	72004	.1	
	3/8"	56	72006	.1	
	1/2"	56	72008	.2	
#3 (.099") 5/64" Key	3/16"	48	72010	.1	100
	1/4"	48	72012	.1	
	3/8"	48	72014	.1	
	1/2"	48	72016	.2	
#4 (.112") 3/32" Key	3/16"	40	86150	.2	100
	1/4"	40	72018	.2	
	5/16"	40	86154	.2	
	3/8"	40	72020	.2	
	1/2"	40	72022	.3	
	5/8"	40	72024	.3	
	3/4"	40	72026	.3	
	7/8"	40	86172	.4	
1"	40	86176	.4		
#5 (.125") 3/32" Key	1/4"	40	72028	.2	100
	3/8"	40	72030	.3	
	1/2"	40	72032	.3	
	5/8"	40	72034	.3	
	3/4"	40	72036	.4	
#6 (.138") 7/64" Key	1/4"	32*	72038	.3	100
	3/8"	32*	72040	.3	
	1/2"	32*	72042	.4	
	5/8"	32*	72044	.4	
	3/4"	32*	72046	.4	
	7/8"	32	72048	.5	
	1"	32	72050	.5	
	1-1/4"	32	86288	.5	
	1-1/2"	32	86292	.6	
	1-3/4"	32	86296	.7	
2"	32	86300	.8		
#8 (.164") 9/64" Key	1/4"	32	72052	.4	100
	3/8"	32*	72054	.5	
	1/2"	32*	72056	.5	
	5/8"	32	72058	.6	
	3/4"	32*	72060	.7	
	7/8"	32	72062	.7	
	1"	32	72064	.8	
	1-1/4"	32	72066	.9	
1-1/2"	32	72068	1.1		

DIAMETER	LENGTH UNDER HEAD	THREAD SERIES UNRC	PRODUCT CODE NUMBER	APPROX. WT. LBS. PER BOX	QTY IN BOX
#8 (Cont.)	1-3/4"	32	86362	1.2	100
	2"	32	86364	1.2	
	2-1/2"	32	86368	1.3	
#10 (.190") 5/32" Key	1/4"	24	86424	.5	100
	3/8"	24*	72070	.6	
	1/2"	24*	72072	.7	
	5/8"	24*	72074	.8	
	3/4"	24*	72076	.9	
	7/8"	24*	72078	.9	
	1"	24*	72080	1.0	
	1-1/4"	24*	72082	1.3	
	1-1/2"	24*	72084	1.4	
	1-3/4"	24*	72086	1.6	
2"	24*	72088	1.9		
1/4" (.250") 3/16" Key	2-1/4"	24*	86440	2.0	100
	2-1/2"	24*	86442	2.1	
	1/4"	20	86526	.8	
	3/8"	20*	72090	1.0	
	1/2"	20*	72092	1.2	
	5/8"	20*	72094	1.4	
	3/4"	20*	72096	1.5	
	7/8"	20*	72098	1.6	
	1"	20*	72100	1.8	
	1-1/4"	20*	72102	2.1	
5/16" (.312") 1/4" Key	1-1/2"	20*	72104	2.5	100
	1-3/4"	20*	72106	2.8	
	2"	20*	72108	3.0	
	2-1/4"	20*	72110	3.4	
	2-1/2"	20	72112	3.8	
	2-3/4"	20	72114	3.9	
	3"	20	72116	4.3	
	3-1/4"	20	86576	4.8	
	3-1/2"	20	72117	5.2	
	3-3/4"	20	86580	5.5	
4"	20	72115	5.7		
5/16" (.312") 1/4" Key	3/8"	18	72118	1.8	100
	1/2"	18*	72120	2.0	
	5/8"	18*	72122	2.3	
	3/4"	18*	72124	2.5	
	7/8"	18*	72126	2.7	
	1"	18*	72128	2.9	

PLEASE ORDER BY PRODUCT CODE NUMBER

*FOR FINE THREAD SERIES SEE PAGES 10 AND 11



Socket Head Cap Screws

UNRC COARSE THREAD SERIES • 1960 SERIES
 HEAT TREATED ALLOY STEEL • UNIFIED 3A THREAD FIT
 MEETS ASME/ANSI B18.3

DIAMETER	LENGTH UNDER HEAD	THREAD SERIES UNRC	PRODUCT CODE NUMBER	APPROX. WT. LBS. PER BOX	QTY IN BOX
5/16" (Cont.)	1-1/4"	18*	72130	3.4	100
	1-1/2"	18*	72132	3.9	
	1-3/4"	18*	72134	4.4	
	2"	18*	72136	4.9	
	2-1/4"	18*	72138	5.4	
	2-1/2"	18*	72140	5.9	
	2-3/4"	18	72142	6.4	50
	3"	18	72144	6.9	
	3-1/4"	18	72146	3.7	
	3-1/2"	18	72148	3.9	
	4"	18	86646	4.5	
3/8" (.375") 5/16" Key	1/2"	16*	72150	3.4	100
	5/8"	16*	72152	3.8	
	3/4"	16*	72154	4.0	
	7/8"	16*	72156	4.3	
	1"	16*	72158	4.6	
	1-1/4"	16*	72160	5.2	
	1-1/2"	16*	72162	6.0	50
	1-3/4"	16*	72164	3.3	
	2"	16*	72166	3.9	
	2-1/4"	16*	72168	4.3	
	2-1/2"	16*	72170	4.5	
	2-3/4"	16	72172	4.9	
	3"	16*	72174	5.1	
	3-1/4"	16	72176	5.4	
	3-1/2"	16	72178	5.8	
	4"	16	72180	6.6	
4-1/2"	16	72182	7.4		
5"	16	72184	8.8		
5-1/2"	16	86688	9.2		
6"	16	72185	9.5		
7/16" (.437") 3/8" Key	1/2"	14	72186	4.9	100
	5/8"	14	72188	5.2	
	3/4"	14	72190	5.6	
	7/8"	14	72192	6.0	
	1"	14*	72194	6.4	
	1-1/4"	14*	72196	3.8	50
	1-1/2"	14*	72198	4.2	
	1-3/4"	14	72200	4.6	
	2"	14*	72202	5.0	
	2-1/4"	14	72204	5.5	
2-1/2"	14	72206	6.0		

DIAMETER	LENGTH UNDER HEAD	THREAD SERIES UNRC	PRODUCT CODE NUMBER	APPROX. WT. LBS. PER BOX	QTY IN BOX
7/16" (Cont.)	2-3/4"	14	72208	3.3	25
	3"	14	72210	3.5	
	3-1/4"	14	72212	4.0	
	3-1/2"	14	72214	4.0	
	4"	14	72216	4.5	
	4-1/2"	14	72271	5.0	
	5"	14	86724	5.5	
1/2" (.500") 3/8" Key	1/2"	13	72218	3.7	50
	5/8"	13	72220	4.0	
	3/4"	13	72222	4.2	
	7/8"	13	72224	4.5	
	1"	13*	72226	4.8	
	1-1/4"	13*	72228	5.3	
	1-1/2"	13*	72230	6.3	25
	1-3/4"	13*	72232	6.6	
	2"	13*	72234	7.4	
	2-1/4"	13*	72236	4.0	
	2-1/2"	13*	72238	4.4	
	2-3/4"	13	72240	4.6	
	3"	13*	72242	4.9	
	3-1/4"	13	72244	5.1	
	3-1/2"	13	72246	6.0	
	3-3/4"	13	72247	6.2	
	4"	13	72248	6.3	
	4-1/2"	13	72250	7.0	
5"	13	72252	7.9		
5-1/2"	13	72254	8.6		
6"	13	72256	9.3		
6-1/2"	13	72258	3.8	10	
7"	13	72260	4.0		
8"	13	72262	4.5		
5/8" (.625") 1/2" Key	1"	11*	72264	4.3	25
	1-1/4"	11*	72266	4.8	
	1-1/2"	11*	72268	5.3	
	1-3/4"	11*	72270	5.6	
	2"	11*	72272	6.0	
	2-1/4"	11	72274	6.8	
	2-1/2"	11*	72276	7.3	
	2-3/4"	11	72278	7.8	
	3"	11	72280	8.4	
	3-1/4"	11	72282	9.0	
3-1/2"	11	72284	9.5		
4"	11	72286	10.5		



Socket Head Cap Screws

UNRC COARSE THREAD SERIES • 1960 SERIES
 HEAT TREATED ALLOY STEEL • UNIFIED 3A THREAD FIT
 MEETS ASME/ANSI B18.3

DIAMETER	LENGTH UNDER HEAD	THREAD SERIES UNRC	PRODUCT CODE NUMBER	APPROX. WT. LBS. PER BOX	QTY IN BOX
5/8" (Cont.)	4-1/2"	11	72288	9.5	20
	5"	11	72290	10.5	
	5-1/2"	11	72292	5.3	10
	6"	11	72294	5.5	
	6-1/2"	11	72296	5.9	
	7"	11	72298	6.3	
	8"	11	72300	7.0	
3/4" (.750") 5/8" Key	1-1/4"	10	72302	7.1	25
	1-1/2"	10	72304	7.6	
	1-3/4"	10	72306	8.4	
	2"	10	72308	9.1	
	2-1/4"	10	72310	9.9	
	2-1/2"	10	72312	10.6	
	2-3/4"	10	72314	11.4	
	3"	10	72316	12.3	
	3-1/4"	10	72318	13.0	20
	3-1/2"	10	72320	13.8	
	3-3/4"	10	72321	14.8	
	4"	10	72322	15.4	
	4-1/2"	10	72324	14.0	
	5"	10	72326	14.7	
	5-1/2"	10	72328	7.9	10
	6"	10	72330	8.4	
	6-1/2"	10	72332	9.0	
	7"	10	72334	9.6	
	8"	10	72336	10.8	
7/8" (.875") 3/4" Key	2"	9	72338	5.1	10
	2-1/4"	9	72340	5.4	
	2-1/2"	9	72342	5.8	
	2-3/4"	9	72344	6.2	
	3"	9	72346	6.6	
	3-1/4"	9	72348	7.1	
	3-1/2"	9	72350	7.6	
	4"	9	72352	8.4	
	4-1/2"	9	72354	9.2	
	5"	9	72356	10.0	
	5-1/2"	9	72358	10.8	
	6"	9	72360	11.6	
	6-1/2"	9	72362	12.5	
	7"	9	72364	13.0	
8"	9	72366	13.6		

DIAMETER	LENGTH UNDER HEAD	THREAD SERIES UNRC	PRODUCT CODE NUMBER	APPROX. WT. LBS. PER BOX	QTY IN BOX
1" (1.000") 3/4" Key	2"	8	72368	7.1	10
	2-1/4"	8	72370	7.6	
	2-1/2"	8	72372	8.1	
	2-3/4"	8	72374	8.5	
	3"	8	72376	9.2	
	3-1/4"	8	72378	9.7	
	3-1/2"	8	72380	10.3	
	4"	8	72382	11.3	
	4-1/2"	8	72384	12.4	
	5"	8	72386	13.5	
	5-1/2"	8	72388	14.6	
	6"	8	72390	15.8	
	6-1/2"	8	72392	16.8	
	7"	8	72394	17.8	
8"	8	72396	19.8		
1-1/4" (1.250") 7/8" Key	UNIFIED 2A THREAD FIT				1
	3"	7	72400	1.6	
	3-1/2"	7	72402	1.8	
	4"	7	72404	2.0	
	4-1/2"	7	72406	2.1	
	5"	7	72408	2.3	
	5-1/2"	7	72410	2.4	
	6"	7	72412	2.6	
	6-1/2"	7	72414	2.8	
	7"	7	72416	2.9	
8"	7	72418	3.3		
9"	7	72420	3.8		
10"	7	72422	4.2		
11"	7	72424	4.6		
1-1/2" (1.500") 1" Key	UNIFIED 2A THREAD FIT				1
	3-1/2"	6	72428	2.5	
	4"	6	72430	2.9	
	4-1/2"	6	72432	3.0	
	5"	6	72434	3.3	
	5-1/2"	6	72436	3.5	
	6"	6	72438	3.8	
	6-1/2"	6	72440	4.0	
	7"	6	72442	4.3	
	8"	6	72444	4.8	

PLEASE ORDER BY PRODUCT CODE NUMBER



Socket Head Cap Screws

UNRF FINE THREAD SERIES • 1960 SERIES
 HEAT TREATED ALLOY STEEL • UNIFIED 3A THREAD FIT
 MEETS ASME/ANSI B18.3

DIAMETER	LENGTH UNDER HEAD	THREAD SERIES UNRF	PRODUCT CODE NUMBER	APPROX. WT. LBS. PER BOX	QTY IN BOX
#0 (.060") .050" Key	1/8"	80	73002	.1	100
	3/16"	80	73004	.1	
	1/4"	80	73006	.1	
	3/8"	80	73008	.1	
#1 (.073") 1/16" Key	1/4"	72	73014	.1	100
	3/8"	72	73016	.1	
#6 (.138") 7/64" Key	1/4"	40	73018	.3	100
	3/8"	40	73020	.3	
	1/2"	40	73022	.4	
	5/8"	40	73024	.4	
#8 (.164") 9/64" Key	3/8"	36	73028	.5	100
	1/2"	36	73030	.5	
	3/4"	36	73032	.7	
#10 (.190") 5/32" Key	1/4"	32	77388	.5	100
	3/8"	32	73034	.6	
	1/2"	32	73036	.7	
	5/8"	32	73038	.8	
	3/4"	32	73040	.9	
	7/8"	32	73042	.9	
	1"	32	73044	1.0	
	1-1/4"	32	73046	1.3	
	1-1/2"	32	73048	1.4	
	1-3/4"	32	73050	1.6	
	2"	32	73052	1.9	
	2-1/4"	32	77440	2.0	
2-1/2"	32	77442	2.2		
3"	32	77446	2.5		
1/4" (.250") 3/16" Key	1/4"	28	77450	.8	100
	3/8"	28	73054	1.0	
	1/2"	28	73056	1.2	
	5/8"	28	73058	1.4	
	3/4"	28	73060	1.5	
	7/8"	28	73062	1.6	
	1"	28	73064	1.8	
	1-1/4"	28	73066	2.1	
1-1/2"	28	73068	2.5		

DIAMETER	LENGTH UNDER HEAD	THREAD SERIES UNRF	PRODUCT CODE NUMBER	APPROX. WT. LBS. PER BOX	QTY IN BOX
1/4" (Cont.)	1-3/4"	28	73070	2.8	100
	2"	28	73072	3.0	
	2-1/4"	28	73074	3.4	
	2-1/2"	28	77474	3.8	
	3"	28	77478	4.3	
5/16" (.312") 1/4" Key	4"	28	77482	5.7	100
	1/2"	24	73076	2.0	
	5/8"	24	73078	2.3	
	3/4"	24	73080	2.5	
	7/8"	24	73082	2.7	
	1"	24	73084	2.9	
	1-1/4"	24	73086	3.4	
	1-1/2"	24	73088	3.9	
	1-3/4"	24	73090	4.4	
	2"	24	73092	4.9	
2-1/4"	24	73094	5.4		
2-1/2"	24	73096	5.9		
3/8" (.375") 5/16" Key	1/2"	24	73098	3.4	100
	5/8"	24	73100	3.8	
	3/4"	24	73102	4.0	
	7/8"	24	73104	4.3	
	1"	24	73106	4.6	
	1-1/4"	24	73108	5.2	
	1-1/2"	24	73110	6.0	
	1-3/4"	24	73112	3.3	
	2"	24	73114	3.9	
	2-1/4"	24	73116	4.3	
	2-1/2"	24	73118	4.5	
	2-3/4"	24	73119	4.9	
3"	24	73120	5.1		
3-1/2"	24	77500	5.8		
4"	24	77504	6.6		
5"	24	77510	8.8		
7/16" (.437") 3/8" Key	1"	20	73122	6.4	100
	1-1/4"	20	73124	3.8	50
	1-1/2"	20	73126	4.2	
	2"	20	73128	5.0	



Socket Head Cap Screws

UNRF FINE THREAD SERIES • 1960 SERIES

HEAT TREATED ALLOY STEEL • UNIFIED 3A THREAD FIT
MEETS ASME/ANSI B18.3

DIAMETER	LENGTH UNDER HEAD	THREAD SERIES UNRF	PRODUCT CODE NUMBER	APPROX. WT. LBS. PER BOX	QTY IN BOX
1/2" (.500") 3/8" Key	1"	20	73130	4.8	50
	1-1/4"	20	73132	5.3	
	1-1/2"	20	73134	6.3	
	1-3/4"	20	73136	6.6	
	2"	20	73138	7.4	
	2-1/4"	20	73140	4.0	25
	2-1/2"	20	73142	4.4	
	2-3/4"	20	73143	4.6	
	3"	20	73144	4.9	
	3-1/2"	20	73145	6.0	
	4"	20	77540	6.3	
	4-1/2"	20	77544	7.0	
	5"	20	77548	7.9	
	5-1/2"	20	77552	8.6	
6"	20	77556	9.3		

DIAMETER	LENGTH UNDER HEAD	THREAD SERIES UNRF	PRODUCT CODE NUMBER	APPROX. WT. LBS. PER BOX	QTY IN BOX
5/8" (.625") 1/2" Key	1"	18	73146	4.3	25
	1-1/4"	18	73148	4.8	
	1-1/2"	18	73150	5.3	
	1-3/4"	18	73152	5.6	
	2"	18	73154	6.0	
	2-1/2"	18	73156	7.3	
	2-1/4"	18	73155	6.8	
	2-3/4"	18	73158	7.8	
	3"	18	73160	8.4	
	3-1/2"	18	73164	9.5	
	4"	18	73168	10.5	
	4-1/2"	18	73172	9.5	20
	5"	18	73176	10.5	

WARNING:

Proper fastener installation is critical to the optimum performance of the Holo-Krome® fastener products.*

Proper selection and use of fastener installation tools is critical to the performance of the fasteners.*

*See Holo-Krome Technical Hand Book for detail specifications.



Socket Head Cap Screws

COARSE AND FINE THREAD SERIES • STAINLESS STEEL
 NON-HEAT TREATED • UNIFIED 3A THREAD FIT
 MEETS ASME/ANSI B18.3

DIAMETER	LENGTH UNDER HEAD	PRODUCT CODE NUMBER		APPROX. WT. LBS. PER BOX	QUANTITY IN BOX
		UNRC	UNRF		
#2 (.086") 56 UNRC 5/64" Key	1/4"	78004	-	.1	100
	3/8"	78006	-	.1	
#4 (.112") 40 UNRC 3/32" Key	1/4"	78010	-	.2	100
	3/8"	78012	-	.2	
	1/2"	78014	-	.3	
#6 (.138") 32 UNRC 7/64" Key	1/4"	78016	-	.3	100
	3/8"	78018	-	.3	
	1/2"	78020	-	.4	
	5/8"	78022	-	.4	
	3/4"	78024	-	.4	
#8 (.164") 32 UNRC 9/64" Key	3/8"	78026	-	.5	100
	1/2"	78028	-	.5	
	5/8"	78030	-	.6	
	3/4"	78032	-	.7	
	1"	78034	-	.8	
#10 (.190") 24 UNRC 32 UNRF 5/32" Key	3/8"	78036	79018	.6	100
	1/2"	78038	79020	.7	
	5/8"	78040	79022	.8	
	3/4"	78042	79024	.9	
	7/8"	78044	-	.9	
	1"	-	79028	1.0	
	1-1/4"	-	79030	1.3	
1-1/2"	-	79032	1.4		
1/4" (.250") 20 UNRC 28 UNRF 3/16" Key	3/8"	78052	-	1.0	100
	1/2"	78054	-	1.2	
	5/8"	78056	79036	1.4	
	3/4"	78058	79038	1.5	

DIAMETER	LENGTH UNDER HEAD	PRODUCT CODE NUMBER		APPROX. WT. LBS. PER BOX	QUANTITY IN BOX
		UNRC	UNRF		
1/4" (Cont.)	7/8"	78060	-	1.6	100
	1"	78062	79040	1.8	
	1-1/4"	78064	-	2.1	
	1-1/2"	78066	-	2.5	
	1-3/4"	78068	-	2.8	
5/16" (.312") 18 UNRC 1/4" Key	2"	78070	-	3.0	100
	1/2"	78072	-	2.0	
	3/4"	78076	-	2.5	
	7/8"	78078	-	2.7	
	1"	78080	-	2.9	
3/8" (.375") 16 UNRC 5/16" Key	1-1/4"	78082	-	3.4	100
	1-1/2"	78084	-	3.9	
	2"	78088	-	4.9	
	1/2"	78090	-	3.4	
	5/8"	78092	-	3.8	
	3/4"	78094	-	4.0	
	1"	78098	-	4.6	
	1-1/4"	78100	-	5.2	
	1-1/2"	78102	-	6.0	
	1-3/4"	78104	-	3.3	
1/2" (.500") 13 UNRC 3/8" Key	2"	78106	-	3.9	50
	2-1/2"	78108	-	4.5	
	1"	78112	-	4.8	
	1-1/4"	78114	-	5.3	
1/2"	1-1/2"	78116	-	6.3	50
	1-3/4"	78118	-	6.6	
	2"	78120	-	7.4	



Low Head Cap Screws

COARSE AND FINE THREAD SERIES
HEAT TREATED ALLOY STEEL • UNIFIED 3A THREAD FIT

DIAMETER	LENGTH UNDER HEAD	PRODUCT CODE NUMBER		APPROX. WT. LBS. PER BOX	QUANTITY IN BOX
		UNRC	UNRF		
#8 (.164") 32 UNRC 5/64" Key	3/8"	68002	-	.3	100
	1/2"	68004	-	.3	
	3/4"	68008	-	.5	
	1"	68010	-	.7	
#10 (.190") 24 UNRC 32 UNRF 3/32" Key	3/8"	68012	69002	.4	100
	1/2"	68014	69004	.5	
	5/8"	-	69006	.6	
	3/4"	68018	69008	.7	
1/4" (.250") 20 UNRC 1/8" Key	3/8"	68022	-	.7	100
	1/2"	68024	-	.8	
	5/8"	68026	-	1.1	
	3/4"	68028	-	1.2	
	1"	68030	-	1.3	

DIAMETER	LENGTH UNDER HEAD	PRODUCT CODE NUMBER		APPROX. WT. LBS. PER BOX	QUANTITY IN BOX
		UNRC	UNRF		
5/16" (.312") 18 UNRC 5/32" Key	1/2"	68032	-	1.4	100
	3/4"	68034	-	1.8	
	1"	68036	-	2.2	
	1-1/4"	68038	-	2.8	
	1-1/2"	68040	-	3.3	
3/8" (.375") 16 UNRC 3/16" Key	1/2"	68042	-	2.2	100
	3/4"	68044	-	2.8	
	1"	68046	-	3.5	
	1-1/4"	68048	-	4.2	
	1-1/2"	68050	-	5.0	
1/2" (.500") 13 UNRC 1/4" Key	1"	68052	-	3.7	50
	1-1/4"	68054	-	4.1	
	1-1/2"	68056	-	4.7	



Flat Head Cap Screws

COARSE AND FINE THREAD SERIES
HEAT TREATED ALLOY STEEL • UNIFIED 3A THREAD FIT
MEETS ASME/ANSI B18.3

DIAMETER	LENGTH OVER-ALL	PRODUCT CODE NUMBER		APPROX. WT. LBS. PER BOX	QUANTITY IN BOX
		UNRC	UNRF		
#4 (.112") 40 UNRC 1/16" Key	1/4"	60002	-	.1	100
	3/8"	60004	-	.2	
	1/2"	60006	-	.2	
	5/8"	60008	-	.2	
	3/4"	60010	-	.3	
#5 (.125") 40 UNRC 5/64" Key	1/4"	60012	-	.1	100
	3/8"	60014	-	.2	
	1/2"	60016	-	.2	
	5/8"	60018	-	.3	
	3/4"	60020	-	.3	

DIAMETER	LENGTH OVER-ALL	PRODUCT CODE NUMBER		APPROX. WT. LBS. PER BOX	QUANTITY IN BOX
		UNRC	UNRF		
#6 (.138") 32 UNRC 5/64" Key	1/4"	60022	-	.2	100
	3/8"	60024	-	.2	
	1/2"	60026	-	.3	
	5/8"	60028	-	.3	
	3/4"	60030	-	.3	
#8 (.164") 32 UNRC 3/32" Key	3/8"	60032	-	.3	100
	1/2"	60034	-	.3	
	5/8"	60036	-	.4	
	3/4"	60038	-	.5	
	1"	60040	-	.6	

PLEASE ORDER BY PRODUCT CODE NUMBER



Flat Head Cap Screws

COARSE AND FINE THREAD SERIES

HEAT TREATED ALLOY STEEL • UNIFIED 3A THREAD FIT
MEETS ASME/ANSI B18.3

DIAMETER	LENGTH OVER-ALL	PRODUCT CODE NUMBER		APPROX. WT. LBS. PER BOX	QUANTITY IN BOX
		UNRC	UNRF		
#10 (.190") 24 UNRC 32 UNRF 1/8" Key	3/8"	60042	61002	.4	100
	1/2"	60044	61004	.5	
	5/8"	60046	61006	.6	
	3/4"	60048	61008	.6	
	1"	60050	61010	.8	
	1-1/4"	60052	61012	1.0	
	1-1/2"	60054	61014	1.2	
1/4" (.250") 20 UNRC 28 UNRF 5/32" Key	3/8"	60056	61016	.8	100
	1/2"	60058	61018	.9	
	5/8"	60060	61020	1.0	
	3/4"	60062	61022	1.2	
	1"	60064	61024	1.4	
	1-1/4"	60066	61026	1.7	
	1-1/2"	60068	61028	2.1	
	1-3/4"	60070	-	2.5	
2"	60072	-	2.8		
5/16" (.312") 18 UNRC 24 UNRF 3/16" Key	1/2"	60074	61030	1.6	100
	5/8"	60076	61032	1.7	
	3/4"	60078	61034	2.0	
	1"	60080	61036	2.4	
	1-1/4"	60082	61038	2.9	
	1-1/2"	60084	-	3.4	
	1-3/4"	60086	-	4.0	
	2"	60088	-	4.5	
	2-1/4"	60090	-	5.1	
	2-1/2"	60092	-	5.5	
3/8" (.375") 16 UNRC 24 UNRF 7/32" Key	1/2"	60094	-	2.3	100
	5/8"	60096	61040	2.8	
	3/4"	60098	61042	3.0	
	1"	60100	61044	3.8	
	1-1/4"	60102	61046	4.5	

DIAMETER	LENGTH OVER-ALL	PRODUCT CODE NUMBER		APPROX. WT. LBS. PER BOX	QUANTITY IN BOX
		UNRC	UNRF		
3/8" (Cont.)	1-1/2"	60104	61048	5.0	100
	1-3/4"	60106	-	3.0	50
	2"	60108	-	3.5	
	2-1/4"	60110	-	3.8	
	2-1/2"	60112	-	4.2	
7/16" (.437") 14 UNRC 1/4" Key	3"	60114	-	4.9	100
	3/4"	60116	-	3.8	
	1"	60118	-	4.8	
1/2" (.500") 13 UNRC 20 UNRF 5/16" Key	1-1/4"	60120	-	2.8	50
	1-1/2"	60122	-	3.4	50
	3/4"	60124	61050	2.4	
	1"	60126	61052	3.0	
	1-1/4"	60128	61054	3.8	
	1-1/2"	60130	61056	4.4	
	1-3/4"	60132	61058	4.9	
	2"	60134	61060	5.5	
	2-1/4"	60136	-	3.3	
	2-1/2"	60138	-	3.6	
3"	60140	-	4.4		
5/8" (.625") 11 UNRC 3/8" Key	1-1/4"	60142	-	3.3	25
	1-1/2"	60144	-	3.8	
	1-3/4"	60146	-	4.3	
	2"	60148	-	4.7	
	2-1/4"	60150	-	5.1	
	2-1/2"	60152	-	5.6	
	3"	60154	-	6.8	
3/4" (.750") 10 UNRC 1/2" Key	1-1/2"	60158	-	5.8	25
	1-3/4"	60160	-	6.5	
	2"	60162	-	7.3	
	2-1/2"	60166	-	8.3	
	3"	60168	-	9.8	



Button Head Cap Screws

COARSE AND FINE THREAD SERIES

HEAT TREATED ALLOY STEEL • UNIFIED 3A THREAD FIT
MEETS ASME/ANSI B18.3

DIAMETER	LENGTH UNDER HEAD	PRODUCT CODE NUMBER		APPROX. WT. LBS. PER BOX	QUANTITY IN BOX
		UNRC	UNRF		
#4 (.112") 40 UNRC 1/16" Key	1/4"	64002	-	.1	100
	3/8"	64004	-	.2	
	1/2"	64006	-	.2	
#6 (.138") 32 UNRC 5/64" Key	1/4"	64008	-	.2	100
	3/8"	64010	-	.2	
	1/2"	64012	-	.3	
	5/8"	64014	-	.3	
#8 (.164") 32 UNRC 3/32" Key	1/4"	64016	-	.3	100
	3/8"	64018	-	.3	
	1/2"	64020	-	.4	
	5/8"	64022	-	.4	
	3/4"	64024	-	.5	
#10 (.190") 24 UNRC 32 UNRF 1/8" Key	1"	88348	-	.7	100
	1/4"	64026	65002	.4	
	3/8"	64028	65004	.4	
	1/2"	64030	65006	.5	
	5/8"	64032	65008	.6	
	3/4"	64034	65010	.7	
	7/8"	64036	65012	.4	
1"	64038	65014	.4		
1/4" (.250") 20 UNRC 28 UNRF 5/32" Key	3/8"	64040	65016	.8	100
	1/2"	64042	65018	.8	
	5/8"	64044	65020	.9	
	3/4"	64046	65022	1.1	

DIAMETER	LENGTH UNDER HEAD	PRODUCT CODE NUMBER		APPROX. WT. LBS. PER BOX	QUANTITY IN BOX
		UNRC	UNRF		
1/4" (Cont.)	7/8"	64048	-	.6	50
	1"	64050	65024	.7	
5/16" (.312") 18 UNRC 24 UNRF 3/16" Key	3/8"	64052	65026	1.1	100
	1/2"	64054	65028	1.4	
	5/8"	64056	65030	1.6	
	3/4"	64058	65032	1.8	50
	7/8"	64060	-	1.0	
1"	64062	65034	1.1		
3/8" (.375") 16 UNRC 24 UNRF 7/32" Key	1/2"	64064	65036	1.1	50
	5/8"	64066	-	1.2	
	3/4"	64068	65037	2.5	
	7/8"	64070	-	1.5	
	1"	64072	65038	1.6	
	1-1/4"	64074	-	2.0	
1/2" (.500") 13 UNRC 5/16" Key	1"	64076	-	1.7	25
	1-1/4"	64078	-	2.0	
	1-1/2"	64080	-	2.3	
	2"	64082	-	3.0	
5/8" (.625") 11 UNRC 3/8" Key	1"	64084	-	2.9	25
	1-1/4"	64086	-	3.3	
	1-1/2"	64088	-	3.8	
	2"	64090	-	4.8	

PLEASE ORDER BY PRODUCT CODE NUMBER



Socket Set Screws

COARSE AND FINE THREAD SERIES

HEAT TREATED ALLOY STEEL • UNIFIED 3A THREAD FIT
MEETS ASME/ANSI B18.3

CUP POINT

DIAMETER	LENGTH OVER-ALL	PRODUCT CODE NUMBER		APPROX. WT. LBS. PER BOX	QTY IN BOX
		UNC	UNF		
#2 (.086") 56 UNC .035" Key	1/16"	32002	-	.1	100
	3/32"	32004	-	.1	
	1/8"	32006	-	.1	
	3/16"	32008	-	.1	
	1/4"	32010	-	.1	
#3 (.099") 48 UNC .050" Key	3/32"	32012	-	.1	100
	1/8"	32014	-	.1	
	1/4"	32018	-	.1	
#4 (.112") 40 UNC 48 UNF .050" Key	1/8"	32020	33020	.1	100
	3/16"	32022	33022	.1	
	1/4"	32024	33024	.1	
	5/16"	32026	-	.1	
	3/8"	32028	-	.1	
	1/2"	32030	-	.1	
	5/8"	32032	-	.2	
#5 (.125") 40 UNC 44 UNF 1/16" Key	1/8"	32034	33026	.1	100
	3/16"	32036	-	.1	
	1/4"	32038	-	.1	
	5/16"	32040	-	.1	
	3/8"	32042	-	.1	
	1/2"	32044	-	.2	
	5/8"	32046	-	.2	
#6 (.138") 32 UNC 40 UNF 1/16" Key	1/8"	32050	33032	.1	100
	3/16"	32052	33034	.1	
	1/4"	32054	33036	.1	
	5/16"	32056	-	.1	
	3/8"	32058	33040	.1	
	1/2"	32060	-	.2	
	5/8"	32062	-	.2	
	3/4"	32064	-	.3	
	7/8"	32066	-	.3	
1"	32068	-	.4		
#8 (.164") 32 UNC 36 UNF 5/64" Key	1/8"	32070	33042	.1	100
	3/16"	32072	33044	.1	
	1/4"	32074	33046	.1	
	5/16"	32076	-	.2	
	3/8"	32078	33050	.2	
	7/16"	32080	-	.2	

DIAMETER	LENGTH OVER-ALL	PRODUCT CODE NUMBER		APPROX. WT. LBS. PER BOX	QTY IN BOX
		UNC	UNF		
#8 (.164") 32 UNC 36 UNF 5/64" Key	1/2"	32082	-	.2	100
	5/8"	32084	-	.3	
	3/4"	32086	-	.3	
	7/8"	32088	-	.4	
	1"	32090	-	.5	
#10 (.190") 24 UNC 32 UNF 3/32" Key	3/16"	32092	33054	.1	100
	1/4"	32094	33056	.1	
	5/16"	32096	33058	.2	
	3/8"	32098	33060	.3	
	1/2"	32100	33062	.3	
	5/8"	32102	33064	.3	
	3/4"	32104	33066	.4	
	7/8"	32106	-	.4	
	1"	32108	33068	.5	
	1-1/4"	32110	33070	.6	
1/4" (.250") 20 UNC 28 UNF 1/8" Key	3/16"	32112	33072	.3	100
	1/4"	32114	33074	.3	
	5/16"	32116	33076	.3	
	3/8"	32118	33078	.4	
	1/2"	32120	33080	.5	
	5/8"	32122	33082	.6	
	3/4"	32124	33084	.8	
	7/8"	32126	-	.9	
	1"	32128	33086	1.0	
	1-1/4"	32130	33088	1.3	
1/4" (.250") 20 UNC 28 UNF 1/8" Key	1-1/2"	32132	-	1.6	50
	1-3/4"	32134	-	.9	
	2"	32136	-	1.0	
5/16" (.312") 18 UNC 24 UNF 5/32" Key	1/4"	32138	33090	.4	100
	5/16"	32140	33092	.4	
	3/8"	32142	33094	.5	
	7/16"	32144	-	.6	
	1/2"	32146	33096	.8	
	5/8"	32148	33098	1.0	
	3/4"	32150	33100	1.2	
	7/8"	32152	-	1.4	
	1"	32154	33102	1.7	
	1-1/4"	32156	-	2.0	
5/16" (.312") 18 UNC 24 UNF 5/32" Key	1-1/2"	32158	-	2.4	50
	1-3/4"	32160	-	1.3	
	2"	32162	-	1.4	



Socket Set Screws

COARSE AND FINE THREAD SERIES

HEAT TREATED ALLOY STEEL • UNIFIED 3A THREAD FIT
MEETS ASME/ANSI B18.3

CUP POINT

DIAMETER	LENGTH OVER-ALL	PRODUCT CODE NUMBER		APPROX. WT. LBS. PER BOX	QUANTITY IN BOX
		UNC	UNF		
3/8" (.375") 16 UNC 24 UNF 3/16" Key	1/4"	32164	33104	.7	100
	5/16"	32166	-	.8	
	3/8"	32168	33106	.9	
	7/16"	32170	-	1.0	
	1/2"	32172	33108	1.1	
	5/8"	32174	33110	1.3	
	3/4"	32176	33112	1.8	
	7/8"	32178	-	2.0	
	1"	32180	33114	2.3	
	1-1/4"	32182	33116	2.9	
	1-1/2"	32184	33118	3.5	
	1-3/4"	32186	-	2.0	50
2"	32188	-	2.3		
2-1/2"	32190	-	3.0		
7/16" (.437") 14 UNC 20 UNF 7/32" Key	3/8"	32192	33120	1.1	100
	7/16"	32194	33122	1.3	
	1/2"	32196	33124	1.4	
	5/8"	32198	-	1.8	
	3/4"	32200	-	2.3	50
	7/8"	32202	-	1.3	
	1"	32204	-	1.5	
	1-1/4"	32206	-	2.0	
	1-1/2"	32208	-	2.4	
	2"	32210	-	3.3	
1/2" (.500") 13 UNC 20 UNF 1/4" Key	3/8"	32212	-	1.5	100
	1/2"	32214	33126	2.0	
	5/8"	32216	-	2.5	
	3/4"	32218	33128	2.8	
	7/8"	32220	-	1.7	50
	1"	32222	33130	2.0	
	1-1/4"	32224	-	2.4	
	1-1/2"	32226	-	3.0	

DIAMETER	LENGTH OVER-ALL	PRODUCT CODE NUMBER		APPROX. WT. LBS. PER BOX	QUANTITY IN BOX
		UNC	UNF		
1/2" (Cont.)	1-3/4"	32228	-	1.8	25
	2"	32230	-	2.1	
	2-1/2"	32232	-	2.6	
5/8" (.625") 11 UNC 18 UNF 5/16" Key	3"	32234	-	3.1	100
	1/2"	32236	-	2.8	
	5/8"	32238	33132	1.8	50
	3/4"	32240	-	2.1	
	1"	32242	33134	3.0	25
	1-1/4"	32244	-	1.9	
	1-1/2"	32246	-	2.4	
	1-3/4"	32248	-	2.9	
	2"	32250	-	3.2	10
	2-1/2"	32252	-	1.7	
	3"	32254	-	2.1	
	3/4" (.750") 10 UNC 3/8" Key	5/8"	32256	-	2.8
3/4"		32258	-	3.3	
1"		32260	-	4.3	
1-1/4"		32262	-	2.7	25
1-1/2"		32264	-	3.4	
1-3/4"		32266	-	1.6	10
2"		32268	-	1.8	
2-1/2"		32270	-	2.4	
3"	32272	-	2.9		
7/8" (.875") 9 UNC 1/2" Key	7/8"	32274	-	.9	10
	1"	32276	-	1.0	
	2-1/2"	32282	-	3.1	
1" (1.000") 8 UNC 9/16" Key	1"	32286	-	1.3	10
	1-1/2"	32288	-	2.2	
	2"	32290	-	3.2	
	3"	32294	-	5.0	

PLEASE ORDER BY PRODUCT CODE NUMBER



Socket Set Screws

COARSE AND FINE THREAD SERIES
HEAT TREATED ALLOY STEEL • UNIFIED 3A THREAD FIT
MEETS ASME/ANSI B18.3

HOLO-KNURL® POINT*

DIAMETER	LENGTH OVER-ALL	PRODUCT CODE NUMBER		APPROX. WT. LBS. PER BOX	QUANTITY IN BOX
		UNC	UNF		
#4 (.112") 40 UNC .050" Key	1/8"	42002	-	.1	100
#6 (.138") 32 UNC 40 UNF 1/16" Key	1/8"	42008	43006	.1	100
	3/16"	42010	-	.1	
	1/4"	42012	-	.1	
#8 (.164") 32 UNC 5/64" Key	1/8"	42014	-	.1	100
	3/16"	42016	-	.1	
	1/4"	42018	-	.1	
	3/8"	42020	-	.2	
#10 (.190") 24 UNC 32 UNF 3/32" Key	3/16"	-	43008	.1	100
	1/4"	42024	43010	.1	
	3/8"	-	43012	.3	
	1/2"	-	43014	.3	

DIAMETER	LENGTH OVER-ALL	PRODUCT CODE NUMBER		APPROX. WT. LBS. PER BOX	QUANTITY IN BOX
		UNC	UNF		
1/4" (.250") 20 UNC 28 UNF 1/8" Key	3/16"	42026	43016	.3	100
	1/4"	42028	43018	.3	
	5/16"	42030	43020	.3	
	3/8"	42032	43022	.4	
	1/2"	42034	-	.5	
5/16" (.312") 18 UNC 24 UNF 5/32" Key	3/4"	42036	-	.8	100
	1/4"	42038	43024	.4	
	5/16"	42040	43026	.4	
	3/8"	42042	43028	.5	
3/8" (.375") 16 UNC 24 UNF 3/16" Key	1/2"	42043	43030	.8	100
	5/8"	42044	-	1.0	
	3/4"	42045	-	1.2	
	1"	42046	-	1.7	
	3/8"	42047	43032	.9	
1/2" (.500") 13 UNC 1/4" Key	1/2"	42048	43034	1.1	100
	3/4"	42049	-	1.8	
	1"	42050	-	2.3	
	1/2"	42052	-	2.0	
1/2" (.500") 13 UNC 1/4" Key	5/8"	42054	-	2.5	50
	3/4"	42056	-	2.8	
	1"	42058	-	2.0	
	1"	42058	-	2.0	

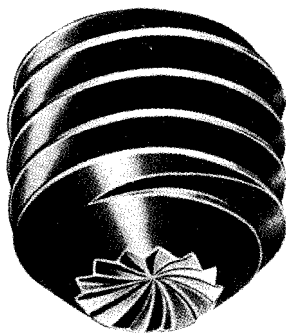

HOLO-KNURL® POINT

INTERNAL KNURL POINT SOCKET SET SCREW — with the following advantages:

- Ratchet Locking Action
- Superior Holding Power
- Thermo-Forged® Point and Socket
- Precision Ground or Rolled Threads
- Heat Treated Alloy Steel

*Holo-Krome Patented, U.S. Patent No. 3,286,754.

Socket Set Screws

COARSE AND FINE THREAD SERIES
HEAT TREATED ALLOY STEEL • UNIFIED 3A THREAD FIT • MEETS ASME/ANSI B18.3



DIAMETER	LENGTH OVER-ALL	FLAT POINT		CONE POINT		OVAL POINT		HALF DOG		APPROX. WT. /LBS. PER BOX	QTY. PER BOX
		PRODUCT CODE NUMBER		PRODUCT CODE NUMBER		PRODUCT CODE NUMBER		PRODUCT CODE NUMBER			
		UNC	UNF	UNC	UNF	UNC	UNF	UNC	UNF		
#4 UNC 40 UNF 48 050" Key	1/8"	36002	-	-	-	-	-	-	-	.1	100
	3/16"	36004	-	-	-	-	-	-	-	.1	
	1/4"	36006	-	-	-	-	-	-	-	.1	
#5 UNC 40 UNF 44 1/16" Key	1/8"	36010	-	-	-	-	-	-	-	.1	100
#6 UNC 32 UNF 40 1/16" Key	1/8"	36014	-	24010	-	-	-	-	-	.1	100
	3/16"	36016	-	24012	-	-	-	-	-	.1	
	1/4"	36018	-	24014	-	-	-	-	-	.1	
	3/8"	36022	-	-	-	-	-	-	-	.1	
#8 UNC 32 UNF 36 5/64" Key	1/8"	36024	-	-	-	-	-	-	-	.1	100
	3/16"	36026	-	-	-	-	-	-	-	.1	
	1/4"	36028	-	24018	-	28006	-	20004	-	.1	
	3/8"	36032	-	24022	-	-	-	20008	-	.2	
	1/2"	36034	-	-	-	-	-	20010	-	.2	
#10 UNC 24 UNF 32 3/32" Key	3/16"	36038	37002	-	25002	-	29002	-	21002	.1	100
	1/4"	36040	37004	24026	25004	-	-	20014	21004	.1	
	5/16"	36042	-	-	-	-	-	-	-	.2	
	3/8"	36044	-	24028	-	-	-	20018	-	.2	
1/4" UNC 20 UNF 28 1/8" Key	3/16"	36050	-	-	-	-	-	-	-	.2	100
	1/4"	36052	37006	24032	25006	-	29006	20022	21006	.2	
	5/16"	36054	-	-	-	-	-	20024	-	.3	
	3/8"	36056	37008	24036	-	28022	-	20026	21008	.4	
	1/2"	36058	-	24038	-	28024	-	20028	-	.5	
	5/8"	36060	-	-	-	-	-	20030	-	.7	
	3/4"	36062	-	24042	-	-	-	20032	-	.8	
1"	36064	-	24044	-	-	-	20034	-	1.1		
5/16" UNC 18 UNF 24 5/32" Key	1/4"	36066	-	-	-	-	-	-	-	.4	100
	5/16"	36068	-	-	-	-	-	20036	-	.4	
	3/8"	36070	37012	24048	-	-	-	20038	21010	.5	
	1/2"	36072	-	24050	-	-	-	20040	-	.8	
	3/4"	-	-	-	-	-	-	20044	-	1.2	
1"	36078	-	-	-	-	-	20046	-	1.6		

PLEASE ORDER BY PRODUCT CODE NUMBER

Socket Set Screws

COARSE AND FINE THREAD SERIES

HEAT TREATED ALLOY STEEL • UNIFIED 3A THREAD FIT • MEETS ASME/ANSI B18.3



DIAMETER	LENGTH	FLAT POINT		CONE POINT		OVAL POINT		HALF DOG		APPROX. WT. LBS. PER BOX	QUANTITY IN BOX
		PRODUCT CODE NUMBER		PRODUCT CODE NUMBER		PRODUCT CODE NUMBER		PRODUCT CODE NUMBER			
		UNC	UNF	UNC	UNF	UNC	UNF	UNC	UNF		
3/8" UNC 16 UNF 24 3/16" Key	1/4"	36080	-	-	-	-	-	-	-	.5	100
	3/8"	36082	37014	24056	-	-	-	20048	-	.8	
	1/2"	36084	37016	24058	-	-	-	20050	21012	1.1	
	5/8"	-	-	-	-	28050	-	20052	-	1.5	
	3/4"	36088	-	-	-	-	-	20054	-	1.8	
	1"	36090	-	-	-	-	-	20056	-	2.5	
	1-1/4"	-	-	-	-	-	-	20058	-	3.3	
1/2" UNC 13 UNF 20 1/4" Key	3/8"	36092	-	-	-	-	-	-	-	1.4	100
	1/2"	36094	37018	-	-	-	-	20060	-	1.8	
	5/8"	-	-	-	-	-	-	20062	-	2.3	
	3/4"	36098	-	-	-	-	-	20064	-	3.1	
	1"	-	-	-	-	28060	-	20066	-	2.0	
	1-1/4"	-	-	-	-	-	-	20068	-	2.4	
5/8" UNC 11 UNF 18 5/16" Key	5/8"	36102	-	-	-	-	-	-	-	2.0	50
	1"	-	-	-	-	-	-	20070	-	3.2	



STAINLESS STEEL — CUP POINT

NON-HEAT TREATED • UNIFIED 3A THREAD FIT

MEETS ASME/ANSI B18.3

DIAMETER	LENGTH	PRODUCT CODE NUMBER		APPROX. WT. LBS. PER BOX	QUANTITY IN BOX
		UNC	UNF		
#4 (.112") 40 UNC .050" Key	1/8"	52018	-	.1	100
	3/16"	52020	-	.1	
	1/4"	52022	-	.1	
#6 (.138") 32 UNC 1/16" Key	1/8"	52024	-	.1	100
	3/16"	52026	-	.1	
	1/4"	52028	-	.1	
#8 (.164") 32 UNC 5/64" Key	1/8"	52034	-	.1	100
	3/16"	52036	-	.1	
	1/4"	52038	-	.1	
	5/16"	52040	-	.2	
	3/8"	52042	-	.2	
#10 (.190") 24 UNC 32 UNF 3/32" Key	1/2"	52044	-	.2	100
	3/16"	-	53022	.1	
	1/4"	52048	53024	.3	
	3/8"	52052	53028	.3	
	1/2"	-	53030	.3	
5/8"	-	53032	.3		

DIAMETER	LENGTH	PRODUCT CODE NUMBER		APPROX. WT. LBS. PER BOX	QUANTITY IN BOX
		UNC	UNF		
1/4" (.250") 20 UNC 1/8" Key	3/16"	52060	-	.3	100
	1/4"	52062	-	.3	
	5/16"	52064	-	.3	
	3/8"	52066	-	.4	
	1/2"	52068	-	.5	
5/16" (.312") 18 UNC 5/32" Key	3/4"	52072	-	.8	100
	1/4"	52076	-	.4	
	5/16"	52078	-	.4	
3/8" (.375") 16 UNC 3/16" Key	3/8"	52080	-	.5	100
	1/2"	52082	-	.8	
	5/16"	52088	-	.9	
1/2" (.500") 13 UNC 1/4" Key	3/8"	52088	-	.9	100
	1/2"	52090	-	1.1	
	3/4"	52092	-	1.8	
1/2" (.500") 13 UNC 1/4" Key	1"	52094	-	2.3	100
	1/2"	52096	-	2.0	
	5/8"	52098	-	2.5	
1/2" (.500") 13 UNC 1/4" Key	3/4"	52100	-	2.8	100
	1/2"	52096	-	2.0	



Socket Jam Screws

HEAT TREATED ALLOY STEEL • UNIFIED 3A THREAD FIT

DIAMETER	LENGTH OVERALL	PRODUCT CODE NUMBER		APPROX. WT. LBS. PER BOX	QUANTITY IN BOX
		UNC	UNF		
#4 (.112") 40 UNC	5/64"	06002	-	.06	100
#8 (.164") 32 UNC	7/64"	06008	-	.06	100
#10 (.190") 24 UNC 32 UNF	1/8"	06010	07010	.09	100
1/4" (.250") 20 UNC 28 UNF	1/8"	06012	07012	.13	100
5/16" (.312") 18 UNC 24 UNF	5/32"	06014	07014	.25	100
3/8" (.375") 16 UNC 24 UNF	3/16"	06016	07016	.37	100

DIAMETER	LENGTH OVERALL	PRODUCT CODE NUMBER		APPROX. WT. LBS. PER BOX	QUANTITY IN BOX
		UNC	UNF		
7/16" (.437") 14 UNC 20 UNF	7/32"	06018	07018	.5	100
1/2" (.500") 13 UNC 20 UNF	1/4"	06020	07020	.81	100
5/8" (.625") 11 UNC 18 UNF	5/16"	06022	07022	1.5	100
3/4" (.750") 10 UNC 16 UNF	3/8"	06024	07024	1.5	50
7/8" (.875") 9 UNC 14 UNF	7/16"	06026	07026	.85	25
1" (1.00") 8 UNC 14 UNF	1/2"	06028	07028	1.3	25



Shoulder Screws

HEAT TREATED ALLOY STEEL • UNIFIED 3A THREAD FIT
MEETS ASME/ANSI B18.3

DIAMETER	SHOULDER LENGTH	PRODUCT CODE NUMBER	APPROX. WT. LBS. PER BOX	QUANTITY IN BOX
1/4" (.246") (.248") 1/8" Key THREAD SERIES #10-24 UNRC	3/8"	08002	.4	25
	1/2"	08004	.4	
	5/8"	08006	.4	
	3/4"	08008	.5	
	1"	08010	.6	
	1-1/4"	08012	.6	
	1-1/2"	08014	.8	

DIAMETER	SHOULDER LENGTH	PRODUCT CODE NUMBER	APPROX. WT. LBS. PER BOX	QUANTITY IN BOX
5/16" (.308") (.310") 5/32" Key THREAD SERIES 1/4-20 UNRC	3/8"	08016	.4	25
	1/2"	08018	.4	
	5/8"	08020	.7	
	3/4"	08022	.8	
	1"	08024	.9	
	1-1/4"	08026	1.0	
	1-1/2"	08028	1.1	
	1-3/4"	08030	1.3	
	2"	08032	1.4	

PLEASE ORDER BY PRODUCT CODE NUMBER



Shoulder Screws

HEAT TREATED ALLOY STEEL • UNIFIED 3A THREAD FIT
MEETS ASME/ANSI B18.3

DIAMETER	SHOULDER LENGTH	PRODUCT CODE NUMBER	APPROX. WT. LBS. PER BOX	QUANTITY IN BOX
3/8" (.371") (.373") 3/16" Key THREAD SERIES 5/16-18 UNRC	3/8"	08034	.9	25
	1/2"	08036	1.0	
	5/8"	08038	1.1	
	3/4"	08040	1.3	
	1"	08042	1.4	
	1-1/4"	08046	1.6	
	1-1/2"	08048	1.9	
	1-3/4"	08049	2.1	
	2"	08050	2.3	
	2-1/4"	08052	2.4	
	2-1/2"	08054	2.6	
	2-3/4"	08056	2.9	
	3"	08058	3.1	
	3-1/4"	08060	3.3	
	3-1/2"	08062	3.5	
4"	08064	3.9		
1/2" (.496") (.498") 1/4" Key THREAD SERIES 3/8-16 UNRC	1/2"	08066	2.0	25
	5/8"	08068	2.3	
	3/4"	08070	2.4	
	1"	08072	2.8	
	1-1/4"	08074	3.1	
	1-1/2"	08076	3.4	
	1-3/4"	08078	3.8	
	2"	08080	4.1	
	2-1/4"	08082	4.5	
	2-1/2"	08084	4.9	
	2-3/4"	08086	5.2	
	3"	08088	5.6	
	3-1/4"	08090	5.9	
	3-1/2"	08092	6.3	
	3-3/4"	08093	6.5	
	4"	08094	7.0	
	4-1/4"	08095	7.2	
4-1/2"	08096	3.0	10	
4-3/4"	08097	3.2		
5"	08098	3.4		

DIAMETER	SHOULDER LENGTH	PRODUCT CODE NUMBER	APPROX. WT. LBS. PER BOX	QUANTITY IN BOX	
5/8" (.621") (.623") 5/16" Key THREAD SERIES 1/2-13 UNRC	1-1/4"	08100	5.0	25	
	1-1/2"	08102	5.6		
	1-3/4"	08104	6.3		
	2"	08106	6.8		
	2-1/4"	08108	7.4		
	2-1/2"	08110	7.9		
	2-3/4"	08112	8.5		
	3"	08114	8.9		
	3-1/4"	08116	9.5		
	3-1/2"	08118	10.0		
	3-3/4"	08117	10.5		
	4"	08120	4.4		10
4-1/4"	08119	4.6			
4-1/2"	08122	5.0			
4-3/4"	08121	5.1			
5"	08124	5.2			
5-1/2"	08123	6.2			
6"	08125	6.6			
3/4" (.746") (.748") 3/8" Key THREAD SERIES 5/8-11 UNRC	1-1/2"	08126	3.6	10	
	1-3/4"	08128	3.8		
	2"	08130	4.0		
	2-1/4"	08132	4.4		
	2-1/2"	08134	4.8		
	2-3/4"	08136	5.0		
	3"	08138	5.4		
	3-1/4"	08139	5.6		
	3-1/2"	08140	6.0		
	3-3/4"	08141	6.3		
	4"	08142	6.6		
	4-1/4"	08143	7.0		
	4-1/2"	08144	7.2		
	4-3/4"	08145	7.6		
5"	08146	7.8			
5-1/2"	08148	8.5			
6"	08150	9.1			



Standard Dowel Pins Black Lustre Finish

.0002 OVER LISTED DIAMETER • RUST RESISTANT
MEETS ASME/ANSI B18.8.2

DIAMETER	LENGTH OVERALL	PRODUCT CODE NUMBER	APPROX. WT. LBS. PER BOX	QUANTITY IN BOX	
1/8"	3/8"	01002	.5	100	
	1/2"	01004	.5		
	5/8"	01006	.5		
	3/4"	01008	.5		
	7/8"	01010	.5		
	1"	01012	.5		
	1-1/4"	01014	.5		
	1-1/2"	01016	.5		
	2"	01020	1.0		
3/16"	1/2"	01022	.5	100	
	5/8"	01024	.5		
	3/4"	01026	.5		
	7/8"	01028	.5		
	1"	01030	1.0		
	1-1/4"	01032	1.5		
	1-1/2"	01034	1.5		
	1-3/4"	01036	1.5		
	2"	01038	1.5		
1/4"	1/2"	01040	1.0	100	
	5/8"	01042	1.0		
	3/4"	01044	1.0		
	7/8"	01046	1.5		
	1"	01048	1.5		
	1-1/4"	01050	2.0		
	1-1/2"	01052	2.0		
	1-3/4"	01054	2.5		
		2"	01056		3.0
		2-1/4"	01058		3.3
	2-1/2"	01060	3.5		
5/16"	1/2"	01062	1.5	100	
	5/8"	01064	1.5		
	3/4"	01066	2.0		
	7/8"	01068	2.0		
	1"	01070	2.0		
	1-1/4"	01072	3.0		
	1-1/2"	01074	3.5		
	1-3/4"	01076	4.0		
		2"	01078		4.5
		2-1/4"	01080		5.0
		2-1/2"	01082		5.5
		3"	01084		6.5

DIAMETER	LENGTH OVERALL	PRODUCT CODE NUMBER	APPROX. WT. LBS. PER BOX	QUANTITY IN BOX	
3/8"	1/2"	01086	2.0	100	
	5/8"	01088	2.0		
	3/4"	01090	2.5		
	7/8"	01092	2.5		
	1"	01094	3.0		
	1-1/4"	01096	4.0		
	1-1/2"	01098	5.0		
		1-3/4"	01100		2.2
		2"	01102		2.6
		2-1/4"	01104		2.8
	2-1/2"	01106	3.2		
	3"	01108	3.8		
7/16"	1"	01110	1.8	40	
	1-1/4"	01112	2.2		
	1-1/2"	01114	2.6		
	2"	01118	3.6		
	2-1/2"	01120	4.4		
	3"	01122	5.2		
1/2"	3/4"	01124	1.8	40	
	1"	01126	2.4		
	1-1/4"	01128	2.8		
	1-1/2"	01130	3.4		
	1-3/4"	01132	4.0		
	2"	01134	4.6		
		2-1/4"	01136		2.6
		2-1/2"	01138		2.8
		3"	01140		3.4
		3-1/2"	01142		4.0
	4"	01144	4.6		
5/8"	1"	01146	.9	10	
	1-1/4"	01148	1.2		
	1-1/2"	01150	1.4		
	1-3/4"	01152	1.6		
	2"	01154	1.8		
	2-1/2"	01158	2.3		
	3"	01160	2.7		
	3-1/2"	01162	3.2		
	4"	01164	3.6		

PLEASE ORDER BY PRODUCT CODE NUMBER



Standard Dowel Pins Black Lustre Finish

.0002 OVER LISTED DIAMETER • RUST RESISTANT
MEETS ASME/ANSI B18.8.2

DIAMETER	LENGTH OVERALL	PRODUCT CODE NUMBER	APPROX. WT. LBS. PER BOX	QUANTITY IN BOX
3/4"	2"	01170	2.5	10
	2-1/2"	01172	3.2	
	3"	01174	3.8	
	3-1/2"	01176	4.4	
	4"	01178	5.1	
7/8"	2"	01186	3.5	10
	2-1/2"	01188	4.4	
	3"	01190	5.3	
	4"	01194	6.9	

DIAMETER	LENGTH OVERALL	PRODUCT CODE NUMBER	APPROX. WT. LBS. PER BOX	QUANTITY IN BOX
1"	2"	01202	4.5	10
	2-1/2"	01204	5.7	
	3"	01206	6.8	
	4"	01210	9.2	



Oversize Dowel Pins Black Lustre Finish

.001 OVER LISTED DIAMETER • RUST RESISTANT
MEETS ASME/ANSI B18.8.2

DIAMETER	LENGTH OVERALL	PRODUCT CODE NUMBER	APPROX. WT. LBS. PER BOX	QUANTITY IN BOX
1/8"	1/2"	03004	.5	100
	3/4"	03008	.5	
	1"	03010	.5	
3/16"	1/2"	03016	.5	100
	1"	03022	1.0	
	1-1/2"	03026	1.5	
1/4"	1/2"	03030	1.0	100
	3/4"	03034	1.0	
	1"	03036	1.5	
	1-1/4"	03038	2.0	
	1-1/2"	03040	2.0	
	2"	03042	3.0	

DIAMETER	LENGTH OVERALL	PRODUCT CODE NUMBER	APPROX. WT. LBS. PER BOX	QUANTITY IN BOX
5/16"	1"	03046	2.0	100
	1-1/2"	03050	3.5	
3/8"	1"	03058	3.0	100
	1-1/4"	03060	4.0	
	1-1/2"	03062	5.0	
1/2"	1"	03070	2.4	40
	1-1/2"	03074	3.4	
	2"	03076	4.6	

WARNING

ALWAYS PRESS DOWEL PINS INTO PLACE USING AN ARBOR PRESS. NEVER STRIKE WITH ANY MATERIAL OR TOOL, INCLUDING A HAMMER. DOING SO MAY CAUSE THE DOWEL TO SPLINTER AND MAY RESULT IN SERIOUS BODILY INJURY.



H-K Pull-Dowels

HEAT TREATED ALLOY STEEL • 6 RMS MICROINCH FINISH
BRIGHT FINISH

HARDNESS: SURFACE-ROCKWELL C 60-64, CORE-ROCKWELL C 50-58
AVG SHEAR STRENGTH: 150,000 psi DIA: .0002 • ROUNDNESS: .00005 T.I.R.

DIAMETER	LENGTH OVERALL	PRODUCT CODE NUMBER	APPROX. WT. LBS. PER BOX	QTY IN BOX
1/4"	3/4"	04002	.2	20
	1"	04006	.3	
	1-1/4"	04008	.7	
	1-1/2"	04012	.4	
	1-3/4"	04014	1.0	
	2"	04016	.6	
5/16"	2-1/2"	04018	1.4	20
	3/4"	04022	.3	
	1"	04026	.4	
	1-1/4"	04028	.6	
	1-1/2"	04030	.7	
3/8"	2"	04034	.9	20
	2-1/2"	04038	1.4	
	1"	04042	.6	
	1-1/4"	04044	.8	
	1-1/2"	04046	.9	
	1-3/4"	04048	1.1	
	2"	04050	1.3	
2-1/4"	04052	3.0		
2-1/2"	04054	1.6		
3"	04056	1.9		

DIAMETER	LENGTH OVERALL	PRODUCT CODE NUMBER	APPROX. WT. LBS. PER BOX	QTY IN BOX
1/2"	1"	04058	1.1	20
	1-1/4"	04060	1.4	
	1-1/2"	04062	1.7	
	1-3/4"	04064	2.0	
	2"	04066	2.2	
	2-1/4"	04068	2.6	
	2-1/2"	04070	2.8	
	3"	04072	3.4	
5/8"	3-1/2"	04074	4.0	10
	1-1/2"	04078	1.3	
	2"	04082	1.8	
	2-1/4"	04084	5.1	
	2-1/2"	04086	2.2	
3/4"	3"	04088	2.7	10
	2"	04094	2.5	
	2-1/2"	04096	3.2	
	3"	04098	3.8	
1"	4"	04100	5.1	10
	2"	04102	4.5	
	3"	04106	6.7	
	4"	04110	9.0	



Holo-Krome Products — *When You Need Them*

All Holo-Krome distributors are STOCKING distributors. They have the Holo-Krome fasteners you need — when you need them. And we supplement their extensive inventories. When you require socket screw fasteners, call your nearest Holo-Krome distributor or call 1-800-866-5753 for the name of the distributor nearest you.



Socket Pressure Plugs

DRYSEAL SOCKET PRESSURE PLUGS

NPTF 3/4" DIAMETRAL TAPER PER FOOT • HEAT TREATED ALLOY STEEL

PRESSURE PLUG SIZE	LENGTH OF PLUG NOMINAL	(NPTF-3/4") THREADS PER INCH	PRODUCT CODE NUMBER	APPROX. WT. LBS. PER BOX	QUANTITY IN BOX
1/16"	5/16"	27	10002	.5	100
1/8"	5/16"	27	10004	.8	
1/4"	7/16"	18	10006	2.0	
3/8"	1/2"	18	10008	4.0	

PRESSURE PLUG SIZE	LENGTH OF PLUG NOMINAL	(NPTF-3/4") THREADS PER INCH	PRODUCT CODE NUMBER	APPROX. WT. LBS. PER BOX	QUANTITY IN BOX
1/2"	9/16"	14	10010	2.9	50
3/4"	5/8"	14	10012	5.1	
1"	3/4"	11 1/2	10014	5.3	25
1-1/4"	13/16"	11 1/2	10016	9.5	

STAINLESS STEEL SOCKET PRESSURE PLUGS

NPTF 3/4" DIAMETRAL TAPER PER FOOT • AUSTENITIC STAINLESS STEEL

PRESSURE PLUG SIZE	LENGTH OF PLUG NOMINAL	(NPTF-3/4") THREADS PER INCH	PRODUCT CODE NUMBER	APPROX. WT. LBS. PER BOX	QUANTITY IN BOX
1/8"	5/16"	27	13002	.8	100

PRESSURE PLUG SIZE	LENGTH OF PLUG NOMINAL	(NPTF-3/4") THREADS PER INCH	PRODUCT CODE NUMBER	APPROX. WT. LBS. PER BOX	QUANTITY IN BOX
1/4"	7/16"	18	13004	2.0	100

FLUSH SOCKET PRESSURE PLUGS

PTF 7/8" DIAMETRAL TAPER PER FOOT • HEAT TREATED ALLOY STEEL

PRESSURE PLUG SIZE	LENGTH OF PLUG NOMINAL	(PTF-7/8") THREADS PER INCH	PRODUCT CODE NUMBER	APPROX. WT. LBS. PER BOX	QUANTITY IN BOX
1/16"	1/4"	27	12002	.5	100
1/8"	1/4"	27	12004	.8	
1/4"	13/32"	18	12006	2.0	

PRESSURE PLUG SIZE	LENGTH OF PLUG NOMINAL	(PTF-7/8") THREADS PER INCH	PRODUCT CODE NUMBER	APPROX. WT. LBS. PER BOX	QUANTITY IN BOX
3/8"	13/32"	18	12008	4.0	100
1/2"	17/32"	14	12010	2.9	50
3/4"	17/32"	14	12012	5.1	

BRASS FLUSH SOCKET PRESSURE PLUGS

PTF 7/8" DIAMETRAL TAPER PER FOOT • COMMERCIAL BRASS

PRESSURE PLUG SIZE	LENGTH OF PLUG NOMINAL	(PTF-7/8") THREADS PER INCH	PRODUCT CODE NUMBER	APPROX. WT. LBS. PER BOX	QUANTITY IN BOX
1/16"	1/4"	27	11100	.5	100
1/8"	1/4"	27	11102	.8	
1/4"	13/32"	18	11104	2.0	

PRESSURE PLUG SIZE	LENGTH OF PLUG NOMINAL	(PTF-7/8") THREADS PER INCH	PRODUCT CODE NUMBER	APPROX. WT. LBS. PER BOX	QUANTITY IN BOX
3/8"	13/32"	18	11106	4.0	100
1/2"	17/32"	14	11108	2.9	50
3/4"	17/32"	14	11110	5.1	

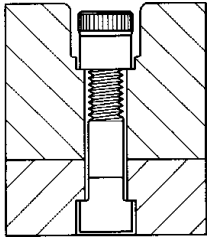

Free application of Allenut in recess with mating member a blind bolt.

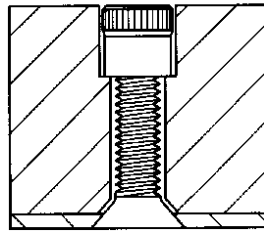

Allenut used free with Flat Head Cap Screw in flush application to obtain surfaces unbroken by projections.

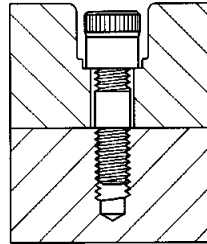

Semi-flush application showing Allenut used free in counterbored hole with stud.

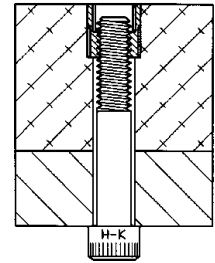

Allenut in anchored position.

Used in non-hardened steel, cast iron, and the softer non-ferrous metals. Allenut can be pressed (or drawn by wrenching mating member) into surrounding material to give a strong, heat-treated thread having greatly increased load-carrying capacity. Allenut can also be molded into plastics, ceramics, fiber and similar materials to provide a high-strength thread.

High quality, multi-purpose, internally-threaded fasteners afford compact holding power.

- 12-point (double-hex) socket has 12 driving points for easier hex key engagement.
- Knurled surface allows finger “spinning” to point where wrenching force is required.
- Allenuts serve as ready-tapped holes, or to replace stripped or worn threads.
- Available in a full range of popular sizes, UNC and UNF thread series. On request, specials can be furnished to meet your design requirements.
- Material: heat-treated steel or austenitic stainless steel.

Allenut Dimension Standards

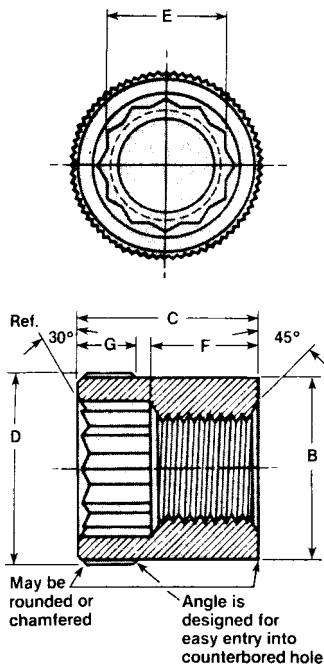

Nom. Nut Size	B		C		D		E	F	G	Min. C'bore Hole Size ¹
	Body Diameter		Length Overall		Knurl Diameter		Socket Size	Thread Length	Knurl Length	
	Max.	Min.	Max.	Min.	Max.	Min.	Nom.	Min.	Min.	
#4	.187	.183	.179	.172	.209	.205	1/8	.080	.046	.202
#5	.187	.183	.205	.198	.209	.205	1/8	.095	.056	.202
#6	.257	.253	.230	.223	.278	.274	5/32	.100	.071	.270
#8	.280	.275	.273	.266	.307	.302	3/16	.125	.084	.298
#10	.307	.302	.319	.309	.336	.331	3/16	.170	.096	.327
1/4	.403	.398	.419	.409	.430	.425	1/4	.225	.136	.42
5/16	.498	.493	.522	.512	.526	.521	5/16	.285	.165	.516
3/8	.590	.585	.621	.606	.620	.615	3/8	.325	.195	.610
7/16	.710	.705	.733	.718	.743	.738	7/16	.360	.235	.733
1/2	.800	.795	.836	.821	.841	.836	1/2	.445	.265	.831
5/8	.986	.980	1.010	.995	1.040	1.034	5/8	.500	.325	1.028
3/4	1.158	1.152	1.185	1.170	1.215	1.209	3/4	.600	.385	1.203
7/8	1.361	1.355	1.358	1.343	1.430	1.424	7/8	.700	.445	1.418
1	1.533	1.527	1.532	1.517	1.620	1.612	1	.810	.495	1.606

¹Dimensions given indicate minimum counterbore hole size in applications where Allenut is to be pressed or drawn into non-hardened materials for anchoring purposes.



Allenuts®

COARSE AND FINE THREADS

MATERIAL: HEAT TREATED STEEL • THREADS: UNC/UNF

DIAMETER THREADS PER INCH	KEY SIZE	PRODUCT CODE NUMBER	PKG. WT., LB	PKG. QTY.
#4-40	1/8	06032	.2	100
#5-40	1/8	06034	.2	
#6-32	5/32	06036	.4	
#8-32	3/16	06038	.4	
#10-24	3/16	06040	.6	
#10-32	3/16	07030	.6	
1/4-20	1/4	06042	1.2	
1/4-28	1/4	07032	1.2	
5/16-18	5/16	06044	2.2	
5/16-24	5/16	07034	2.2	
3/8-16	3/8	06046	3.2	
3/8-24	3/8	07036	3.2	

DIAMETER THREADS PER INCH	KEY SIZE	PRODUCT CODE NUMBER	PKG. WT., LB	PKG. QTY.
7/16-14	7/16	06048	3.4	50
7/16-20	7/16	07038	3.4	
1/2-13	1/2	06050	4.8	
1/2-20	1/2	07040	4.8	
5/8-11	5/8	06052	9.0	
5/8-18	5/8	07042	9.0	
3/4-10	3/4	06054	13.6	
3/4-16	3/4	07044	13.6	
7/8-9	7/8	06056	10.4	
7/8-14	7/8	07046	10.4	
1-8	1	06058	14.8	
1-14	1	07048	14.8	



Stainless Allenuts®

COARSE AND FINE THREADS

MATERIAL: AUSTENITIC STAINLESS STEEL • THREADS: UNC/UNF

DIAMETER THREADS PER INCH	KEY SIZE	PRODUCT CODE NUMBER	PKG. WT., LB	PKG. QTY.
#4-40	1/8	06070	.2	100
#6-32	5/32	06072	.4	
#8-32	3/16	06074	.4	
#10-24	3/16	06076	.6	

DIAMETER THREADS PER INCH	KEY SIZE	PRODUCT CODE NUMBER	PKG. WT., LB	PKG. QTY.
#10-32	3/16	07060	.6	100
1/4-20	1/4	06078	1.2	
5/16-18	5/16	06080	2.2	
3/8-16	3/8	06082	3.2	



Metric Socket Head Cap Screws

HEAT TREATED ALLOY STEEL TO GRADE 12.9
ISO METRIC THREADS TO ANSI B1.13M

DIAMETER	LENGTH UNDER HEAD	PRODUCT CODE NUMBER	APPROX. WT. LBS. PER BOX	QTY PER BOX
M2 Pitch .4 1.5mm Key	4	76604	.1	100
	5	76605	.1	
	6	76606	.1	
	8	76608	.1	
	10	76610	.1	
	12	76612	.1	
M2.5 Pitch .45 2.0mm Key	5	76655	.1	100
	6	76656	.1	
	8	76658	.1	
	10	76660	.1	
	12	76662	.1	
M3 Pitch 0.50 2.5mm Key	5	76004	.1	100
	6	76008	.1	
	8	76012	.2	
	10	76016	.2	
	12	76020	.2	
	15*	76026	.2	
	16	76028	.2	
	20	76032	.3	
	25	76036	.3	
	30	76040	.4	
35	76044	.5		
M4 Pitch 0.70 3mm Key	5	76048	.3	100
	6	76052	.3	
	8	76056	.3	
	10	76060	.4	
	12	76064	.4	
	14*	76066	.5	
	15*	76068	.5	
	16	76072	.5	
	20	76076	.6	
	25	76080	.7	
	30	76084	.8	
	35	76088	.9	
	40	76092	1.0	
	45	76096	1.0	
	50	76100	1.0	

DIAMETER	LENGTH UNDER HEAD	PRODUCT CODE NUMBER	APPROX. WT. LBS. PER BOX	QTY PER BOX
M5 Pitch 0.80 4mm Key	6	76102	.5	100
	8	76104	.5	
	10	76108	.6	
	12	76112	.6	
	14*	76114	.7	
	15*	76118	.7	
	16	76120	.7	
	18*	76122	.7	
	20	76124	.7	
	22*	76126	.9	
	25	76128	.9	
	30	76132	1.0	
	35	76136	1.4	
	40	76140	1.5	
	45	76144	1.7	
	50	76148	1.9	
	55	76149	2.0	
	60	76150	2.0	
65	76151	3.0		
70	76147	3.0		
80	76721	3.0		
90	76722	3.3		
M6 Pitch 1.00 5mm Key	8	76152	.9	100
	10	76156	1.0	
	12	76160	1.0	
	14*	76162	1.0	
	15*	76166	1.0	
	16	76168	1.0	
	18*	76170	1.2	
	20	76172	1.4	
	22*	76174	1.5	
	25	76176	1.6	
	30	76180	1.8	
	35	76184	2.0	
	40	76188	2.4	
	45	76192	2.6	
	50	76196	2.9	
55	76200	3.0		
60	76204	3.0		
65	76208	3.6		
70	76212	3.8		
75	76216	3.9		

*Denotes Non-ANSI Standard

PLEASE ORDER BY PRODUCT CODE NUMBER



Metric Socket Head Cap Screws

HEAT TREATED ALLOY STEEL TO GRADE 12.9
ISO METRIC THREADS TO ANSI B1.13M

DIAMETER	LENGTH UNDER HEAD	PRODUCT CODE NUMBER	APPROX. WT. LBS. PER BOX	QTY PER BOX	
M6 Pitch 1.00 5mm Key	80	76217	4.0	100	
	90	76218	4.8		
	100	76219	5.0		
	110	76215	6.0		
M8 Pitch 1.25 6mm Key	10	76220	2.2	100	
	12	76224	2.4		
	14*	76228	2.6		
	15*	76230	2.6		
	16	76232	2.6		
	18*	76234	2.9		
	20	76236	2.4		
	22*	76238	3.2		
	25	76240	3.4		
	30	76244	3.7		
	35	76248	4.0		
	40	76252	4.6		
	45	76256	5.0		
	50	76260	5.5		100
	55	76264	5.9		
	60	76268	6.0		
	65	76272	6.8		
70	76276	7.2			
75	76280	7.6			
80	76279	8.0			
90	76281	9.0			
100	76282	10.0			
110	76283	10.7			
120	76278	11.6	100		
130	76730	12.8			
140	76734	13.8			
150	76738	14.9			
M10 Pitch 1.50 8mm Key	10	76286		4.0	100
	12	76284		4.0	
	15*	76290		4.6	
	16	76292	4.6		
	18*	76294	4.9		
	20	76296	5.0		
	22*	76298	5.5		
	25	76300	5.7		
	30	76304	6.1		
	35	76308	6.8		

DIAMETER	LENGTH UNDER HEAD	PRODUCT CODE NUMBER	APPROX. WT. LBS. PER BOX	QTY PER BOX
M10 (Cont.)	40	76312	7.5	100
	45	76316	8.0	
	50	76320	8.8	
	55	76324	9.6	
	60	76328	5.1	
	65	76332	5.4	
	70	76336	5.8	
	75	76340	6.1	
	80	76344	6.4	
	90	76348	7.1	
	100	76352	7.8	
	110	76353	8.5	
	120	76357	9.0	
	130	76354	9.9	
	150	76355	11.2	
M12 Pitch 1.75 10mm Key	12	76780	6.4	100
	15*	76782	6.8	
	16	76784	6.9	
	20	76356	7.0	
	25	76360	7.8	
	30	76364	8.6	
	35	76368	9.4	50
	40	76372	5.2	
	45	76376	5.7	
	50	76380	6.1	
	55	76384	6.6	
	60	76388	7.1	
	65	76392	7.6	
	70	76396	8.1	
	75	76400	8.6	25
	80	76404	9.0	
	90	76408	5.0	
	100	76412	5.5	
	110	76416	6.0	10
120	76420	6.4		
130	76421	6.9		
140	76418	7.5	10	
150	76422	6.0		
160	76419	8.0		

*Denotes Non-ANSI standard



Metric Socket Head Cap Screws

HEAT TREATED ALLOY STEEL TO GRADE 12.9
ISO METRIC THREADS TO ANSI B1.13M

DIAMETER	LENGTH UNDER HEAD	PRODUCT CODE NUMBER	APPROX. WT. LBS. PER BOX	QTY PER BOX	
M16 Pitch 2.00 14mm Key	25	76423	4.2	25	
	30	76424	4.2		
	35	76428	4.8		
	40	76432	5.0		
	45	76436	5.3		
	50	76440	5.8		
	55	76444	6.2		
	60	76448	6.7		
	65	76452	7.1		
	70	76456	7.5		
	75	76460	8.0		
	80	76464	8.5		
	90	76468	9.3		
	10	100	76472	4.0	
		110	76476	4.4	
		120	76480	4.7	
		130	76478	5.1	
		140	76479	5.5	
150		76481	5.8		
160		76482	6.0		
180		76483	6.2		
M20 Pitch 2.50 17mm Key		30	76800	16.0	50
		35	76804	3.2	10
	40	76484	3.2		
	45	76488	3.5		
	50	76492	3.8		
	55	76496	4.0		
	60	76500	4.3		
	65	76504	4.5		
	70	76508	4.8		
	75	76512	5.1		
	80	76516	5.4		
	90	76520	5.9		
	100	76524	6.4		
	110	76528	7.0		
	120	76532	7.6		
130	76536	8.1			
140	76537	8.7			
150	76540	9.2			

DIAMETER	LENGTH UNDER HEAD	PRODUCT CODE NUMBER	APPROX. WT. LBS. PER BOX	QTY PER BOX	
M20 (Cont.)	160	76541	9.7	10	
	180	76542	9.9		
	200	76543	12.0		
M24 Pitch 3.00 19mm Key	40	76808	15.5	25	
	50	76544	6.9	10	
	55	76810	7.3		
	60	76548	7.6		
	65	76552	7.9		
	70	76556	8.2		
	80	76560	8.9		
	90	76564	9.6		
	100	76568	10.7		
	110	76569	11.5		
	120	76572	12.3		
	130	76573	13.0		
	140	76574	13.8		
	5	150	76576	7.3	
		160	76577	7.7	
		180	76578	8.5	
		200	76579	9.3	
		220	76580	10.1	
240		76581	2.3		
M30 Pitch 3.5 22mm Key	260	76583	2.4	1	
	80	76584	15.6	10	
	90	76585	16.9		
	100	76586	18.2		
	5	110	76587	9.8	
		120	76592	10.4	
		130	76588	11.0	
		140	76593	11.6	
		1	150	76589	2.5
			160	76594	2.6
180			76590	2.9	
200			76591	3.1	
220			76595	3.4	
240			76596	3.6	
300	76598		4.3		

PLEASE ORDER BY PRODUCT CODE NUMBER



Metric Socket Head Cap Screws

HEAT TREATED ALLOY STEEL TO GRADE 12.9
ISO METRIC THREADS TO ANSI B1.13M

DIAMETER	LENGTH UNDER HEAD	PRODUCT CODE NUMBER	APPROX. WT. LBS. PER BOX	QTY PER BOX
M36 Pitch 4 27mm Key	80	76900	12.2	5
	90	76902	2.7	1
	100	76906	2.8	
	110	76910	3.0	
	120	76914	3.3	
	130	76918	3.4	
	140	76922	3.6	
	150	76926	3.8	
	160	76930	4.0	
	170	76934	4.2	
	180	76938	4.4	
	200	76942	4.7	
	240	76946	5.4	
	260	76950	5.8	



Blue Metric Cap Screws

HEAT TREATED ALLOY STEEL TO GRADE 12.9
ISO METRIC THREADS TO ANSI B1.13M

DIAMETER	LENGTH UNDER HEAD	PRODUCT CODE NUMBER	APPROX. WT. LBS. PER BOX	QTY PER BOX
M3 Pitch 0.50 2.5mm Key	6	76008B	.1	100
	8	76012B	.2	
	10	76016B	.2	
	12	76020B	.2	
	16	76028B	.2	
	20	76032B	.3	
M4 Pitch 0.70 3mm Key	6	76052B	.3	100
	8	76056B	.3	
	10	76060B	.4	
	12	76064B	.4	
	15	76068B	.5	
	16	76072B	.5	
	20	76076B	.6	
	25	76080B	.7	
	30	76084B	.8	
	40	76092B	1.0	
50	76100B	1.0		

DIAMETER	LENGTH UNDER HEAD	PRODUCT CODE NUMBER	APPROX. WT. LBS. PER BOX	QTY PER BOX
M5 Pitch 0.80 4mm Key	8	76104B	.5	100
	10	76108B	.6	
	12	76112B	.6	
	16	76120B	.6	
	20	76124B	.7	
	25	76128B	.9	
	30	76132B	1.0	
	35	76136B	1.4	
	40	76140B	1.5	
	45	76144B	1.7	
	50	76148B	1.9	



Blue Metric Cap Screws

HEAT TREATED ALLOY STEEL TO GRADE 12.9
ISO METRIC THREADS TO ANSI B1.13M

DIAMETER	LENGTH UNDER HEAD	PRODUCT CODE NUMBER	APPROX. WT. LBS. PER BOX	QTY PER BOX
M6 Pitch 1.00 5mm Key	8	76152B	.9	100
	10	76156B	1.0	
	12	76160B	1.0	
	14	76162B	1.0	
	15	76166B	1.0	
	16	76168B	1.0	
	18	76170B	1.2	
	20	76172B	1.4	
	25	76176B	1.6	
	30	76180B	1.8	
	35	76184B	2.0	
	40	76188B	2.4	
	50	76196B	2.9	
	60	76204B	3.0	
M8 Pitch 1.25 6mm Key	75	76216B	3.9	100
	80	76217B	4.0	
	10	76220B	2.2	
	12	76224B	2.5	
	16	76232B	2.6	
	18	76234B	2.9	
	20	76236B	2.4	
	22	76238B	3.2	
	25	76240B	3.4	
	30	76244B	3.7	
	35	76248B	4.0	
	40	76252B	4.6	
	45	76256B	5.0	
	50	76260B	5.5	
	55	76264B	5.9	
	60	76268B	6.0	
	65	76272B	6.8	
	70	76276B	7.2	
75	76281B	7.6		
80	76279B	8.0		
90	76280B	9.0		
110	76283B	10.7		

DIAMETER	LENGTH UNDER HEAD	PRODUCT CODE NUMBER	APPROX. WT. LBS. PER BOX	QTY PER BOX	
M10 Pitch 1.50 8mm Key	10	76286B	4.0	100	
	16	76292B	4.6		
	20	76296B	5.0		
	22	76298B	5.5		
	25	76300B	5.7		
	30	76304B	6.1		
	35	76308B	6.8		
	40	76312B	7.5		
	45	76316B	8.0		
	50	76320B	8.8		50
	60	76328B	5.1		
	70	76336B	5.8		
	80	76344B	6.4		
90	76348B	7.1			
100	76352B	7.8			
130	76354B	9.9			
M12 Pitch 1.75 10mm Key	20	76356B	7.0	100	
	25	76360B	7.8		
	30	76364B	8.6		
	35	76368B	9.4		
	40	76372B	5.2		50
	45	76376B	5.7		
	50	76380B	6.1		
	55	76384B	6.6		
	60	76388B	7.1		
	65	76392B	7.6		
	70	76396B	8.4		
	75	76400B	8.6		
	80	76404B	5.0	25	
	100	76412B	5.5		
	110	76416B	6.0		
150	76422B	6.0	10		

PLEASE ORDER BY PRODUCT CODE NUMBER



Blue Metric Cap Screws

HEAT TREATED ALLOY STEEL TO GRADE 12.9
ISO METRIC THREADS TO ANSI B1.13M

DIAMETER	LENGTH UNDER HEAD	PRODUCT CODE NUMBER	APPROX. WT. LBS. PER BOX	QTY PER BOX
M16 Pitch 2.00 14mm Key	30	76424B	4.2	25
	35	76428B	4.8	
	40	76432B	5.0	
	45	76436B	5.3	
	50	76440B	5.8	
	55	76444B	6.2	
	60	76448B	6.7	
	65	76452B	7.1	
	70	76456B	7.5	
	80	76464B	8.5	
	90	76468B	9.3	
	M20 Pitch 2.50 17mm Key	100	76472B	4.0
110		76476B	4.4	
120		76480B	4.7	
130		76478B	5.1	
150		76481B	6.0	
40		76484B	3.7	10
50		76492B	4.0	10
60	76500B	4.3		
70	76508B	4.8		
80	76516B	5.4	10	
90	76520B	5.9		
100	76524B	6.4		
	140	76537B	8.7	10
	150	76540B	9.2	

DIAMETER	LENGTH UNDER HEAD	PRODUCT CODE NUMBER	APPROX. WT. LBS. PER BOX	QTY PER BOX
M24 Pitch 3.00 19mm Key	70	76556B	8.2	10
	80	76560B	8.9	
	90	76564B	9.6	
	100	76568B	10.7	
	110	76569B	11.5	
	120	76572B	12.3	
	130	76573B	13.0	
	140	76574B	13.8	
	150	76576B	7.3	5
M30 Pitch 3.5 22mm Key	80	76584B	15.6	10
	100	76586B	18.2	



Metric Low Head Cap Screws

COARSE AND FINE THREAD SERIES
HEAT TREATED ALLOY STEEL • UNIFIED 3A THREAD FIT

DIAMETER	LENGTH OVERALL	PRODUCT CODE NUMBER	APPROX. WT. LBS. PER BOX	Qty IN BOX
M4 Pitch 0.70 2.55mm Key	8	69304	.3	100
	10	69308	.3	
	12	69312	.3	
	16	69320	.4	
	20	69328	.5	
	25	69332	.6	
M5 Pitch 0.80 3mm Key	8	69350	.5	100
	10	69354	.6	
	12	69358	.6	
	16	69370	.7	
	20	69374	.8	
	25	69378	.5	
M6 Pitch 1.00 4mm Key	10	69394	.8	100
	12	69398	.9	
	16	69410	1.1	
	20	69414	1.2	
	25	69418	1.4	
	30	69422	1.6	
	35	69426	1.9	
	40	69430	2.2	
	45	69434	2.4	

DIAMETER	LENGTH OVERALL	PRODUCT CODE NUMBER	APPROX. WT. LBS. PER BOX	Qty IN BOX
M8 Pitch 1.25 5mm Key	16	69458	2.1	100
	20	69462	2.4	
	25	69466	2.8	
M10 Pitch 1.50 6mm Key	20	69508	4.2	100
	40	69524	3.2	50
M12 Pitch 1.75 8mm Key	20	69550	3.1	50
	25	69554	3.5	
	35	69562	4.3	
	50	69574	2.7	25
	80	69582	4.3	
M16 Pitch 2.00 10mm Key	30	69590	1.7	10
	35	69594	1.8	
	40	69598	1.9	
	45	69602	2.1	
	60	69610	2.5	
	70	69614	3.0	



Metric Flat Head Cap Screws

HEAT TREATED ALLOY STEEL ISO METRIC THREADS TO ANSI B1.13M

DIAMETER	LENGTH OVERALL	PRODUCT CODE NUMBER	APPROX. WT. LBS. PER BOX	QTY PER BOX
M3 Pitch 0.50 2mm Key	6	87003	.1	100
	8	87004	.1	
	10	87008	.1	
	12	87012	.1	
	15	87014	.1	
	16	87016	.1	
	20	87020	.2	
	25	87021	.3	
M4 Pitch 0.70 2.55mm Key	8	87024	.2	100
	10	87028	.2	
	12	87032	.3	
	15	87034	.3	
	16	87036	.3	
	20	87040	.4	
	25	87044	.5	
	30	87048	.6	
	35	87049	.7	
	40	87050	.9	
M5 Pitch 0.80 3mm Key	8	87052	.3	100
	10	87056	.4	
	12	87060	.4	
	15	87062	.5	
	16	87064	.5	
	20	87068	.7	
	25	87072	.8	
	30	87076	.9	
	35	87077	1.3	
	40	87078	1.4	
	50	87079	1.8	
M6 Pitch 1.00 4mm Key	10	87084	.6	100
	12	87088	.7	
	15	87090	.8	
	16	87092	.8	
	20	87096	1.0	
	25	87100	1.1	
	30	87104	1.3	
	35	87108	1.5	
	40	87112	1.7	
	45	87113	2.1	
	50	87114	2.5	
	60	87115	2.8	

DIAMETER	LENGTH OVERALL	PRODUCT CODE NUMBER	APPROX. WT. LBS. PER BOX	QTY PER BOX
M8 Pitch 1.25 5mm Key	12	87120	1.3	100
	15	87122	1.5	
	16	87124	1.6	
	20	87128	1.9	
	25	87132	2.2	
	30	87136	2.5	
	35	87140	2.9	
	40	87144	3.2	
	45	87143	3.9	
	50	87145	4.4	
	60	87146	5.5	
	70	87147	6.6	
M10 Pitch 1.50 6mm Key	15	87151	2.5	100
	16	87149	2.6	
	20	87152	3.1	
	25	87156	3.6	
	30	87160	3.1	
	35	87164	4.6	
	40	87168	5.2	
	45	87172	6.4	
	50	87176	7.0	
	60	87177	8.0	
	70	87178	4.6	50
	90	87175	6.0	
M12 Pitch 1.75 8mm Key	20	87180	4.6	100
	25	87184	5.4	
	30	87188	6.2	
	35	87192	7.0	
	40	87196	7.8	
	45	87200	4.7	
	50	87204	4.7	
	55	87205	5.0	
	60	87206	6.0	
	70	87198	7.0	
90	87202	8.0		
M16 Pitch 2.00 10mm Key	30	87207	5.6	50
	35	87208	6.4	
	40	87212	3.5	25
	45	87213	4.2	
	50	87216	4.3	
	60	87220	5.0	
	70	87221	6.3	



Metric Button Head Cap Screws

HEAT TREATED ALLOY STEEL
ISO METRIC THREADS TO ANSI B1.13M

DIAMETER	LENGTH OVERALL	PRODUCT CODE NUMBER	APPROX. WT. LBS. PER BOX	QTY PER BOX
M3 Pitch 0.50 2mm Key	6	86002	.1	100
	8	86001	.1	
	10	86003	.1	
	12	86005	.2	
	14	86004	.2	
	16	86006	.2	
M4 Pitch 0.70 2.55mm Key	8	86007	.3	100
	10	86009	.3	
	12	86011	.3	
	15	86012	.4	
	16	86013	.4	
M5 Pitch 0.80 3mm Key	10	86015	.5	100
	12	86017	.5	
	15	86018	.6	
	16	86019	.6	
	20	86021	.8	
	30	86025	1.0	
M6 Pitch 1.00 4mm Key	10	86027	.7	100
	12	86029	.7	
	15	86030	.8	
	16	86031	.9	
	18	86032	0.8	
	22	86034	1.1	

DIAMETER	LENGTH OVERALL	PRODUCT CODE NUMBER	APPROX. WT. LBS. PER BOX	QTY PER BOX
M6 Pitch 1.00 4mm Key	25	86035	1.2	100
	30	86037	1.6	
M8 Pitch 1.25 5mm Key	10	86039	1.0	100
	12	86041	1.2	
	15	86042	1.5	
	16	86043	1.5	
	18	86044	1.7	
	20	86045	1.9	
	25	86047	2.3	
	30	86049	2.8	
M10 Pitch 1.50 6mm Key	35	86050	3.2	100
	40	86051	3.6	
	15	86052	3.0	
	16	86053	3.2	
	20	86055	3.7	
	25	86057	4.2	
M12 Pitch 1.75 8mm Key	30	86059	4.3	100
	35	86060	4.7	
	40	86061	5.0	
	16	86062	4.2	
	20	86063	2.8	
M12 Pitch 1.75 8mm Key	25	86065	3.2	50
	30	86070	3.2	
	35	86075	3.6	
	40	86080	4.0	
	50	86085	4.8	



Metric Cup Point Socket Set Screws

HEAT TREATED ALLOY STEEL TO ROCKWELL C45 MIN.
ISO METRIC THREADS TO ANSI B1.13M

DIAMETER	LENGTH OVERALL	PRODUCT CODE NUMBER	APPROX. WT. LBS. PER BOX	QTY PER BOX
M3 Pitch 0.50 1.5mm Key	3	48004	.03	100
	4	48008	.03	
	5	48012	.04	
	6	48016	.05	
	8	48020	.07	
	10	48024	.09	
M4 Pitch 0.70 2mm Key	12	48028	.10	100
	4	48032	.05	
	5	48036	.06	
	6	48040	.06	
	8	48044	.10	
	10	48048	.10	
	12	48052	.20	
	16	48060	.20	
M5 Pitch 0.80 2.5mm Key	20	48064	.30	100
	25	48068	.40	
	5	48072	.09	
	6	48076	.10	
	8	48080	.20	
	10	48084	.20	
	12	48088	.30	
	16	48096	.40	
M6 Pitch 1.00 3mm Key	20	48100	.50	100
	25	48104	.60	
	6	48108	.1	
	8	48112	.2	
	10	48116	.3	
	12	48120	.4	
	16	48128	.5	
	20	48132	.7	
	25	48136	.9	
	30	48140	1.1	
M8 Pitch 1.25 4mm Key	35	48144	1.4	100
	40	48148	1.6	
	8	48152	.40	
	10	48156	.50	
	12	48160	.60	
	16	48168	.90	
M8 Pitch 1.25 4mm Key	20	48172	1.0	100
	25	48176	1.5	

DIAMETER	LENGTH OVERALL	PRODUCT CODE NUMBER	APPROX. WT. LBS. PER BOX	QTY PER BOX
M8 Pitch 1.25 4mm Key	30	48180	1.9	100
	35	48184	2.2	
	40	48188	2.6	
	45	48192	3.1	
	50	48196	3.4	
M10 Pitch 1.50 5mm Key	10	48200	.7	100
	12	48204	.9	
	16	48212	1.4	
	20	48216	1.8	
	25	48220	2.4	
	30	48224	2.9	
	35	48228	3.5	
	40	48232	4.1	
	45	48236	4.6	
M12 Pitch 1.75 6mm Key	50	48240	5.0	100
	12	48244	1.3	
	16	48252	2.0	
	20	48256	2.6	
	25	48260	3.4	
	30	48264	4.2	
	35	48268	5.0	
	40	48272	3.0	
	45	48276	3.5	
	50	48280	4.0	
M16 Pitch 2.00 8mm Key	16	48284	1.6	50
	20	48288	2.2	
	25	48292	2.9	
	30	48296	3.6	
	35	48300	4.4	
	40	48304	5.1	
	45	48308	5.8	
	50	48312	6.5	
	55	48316	3.6	
	60	48320	4.0	
	M20 Pitch 2.50 10mm Key	20	48324	
25		48328	4.4	
30		48332	5.4	
35		48336	3.3	
40		48340	3.8	
50		48348	5.0	
60		48356	6.5	



Semi-Standard Fasteners

PLEASE ORDER BY PRODUCT CODE NUMBER



Socket Head Cap Screws

HEAT TREATED ALLOY STEEL • UNIFIED 3A THREAD FIT
Meets ASME/ANSI B18.3 • Meets ASTM A574

NON-STANDARD LENGTHS - UNRC

DIAMETER	LENGTH UNDER HEAD	THREAD SERIES UNRC	PRODUCT CODE NUMBER	APPROX. WT. LBS. PER BOX	QTY IN BOX
#4 (.112") 3/32" Key	1-1/4	40	720000270	.5	100
	5/16	40	720000290	.3	100
#5 (.125") 3/32" Key	1	40	720000370	.5	
	#6 (.138") 7/64" Key	5/16	32	720000390	.3
#8 (.164") 9/64" Key		5/16	32	720000530	.5
	#10 (.190") 5/32" Key	2-3/4	24	720000891	2.4
3		24	720000893	2.5	
1/4" (.250") 3/16" Key	4-1/2	20	720001177	3.1	50
	5/16" (.312") 1/4" Key	3-3/4	18	720001491	4.2
3/8" (.375") 5/16" Key		3-3/4	16	720001790	6.2
	1/2" (.500") 3/32" Key	4-1/4	13	720002490	2.7
4-3/4		13	720002510	3.0	
5-1/4		13	720002530	3.2	
5-3/4		13	720002551	3.5	
6-1/4		13	720002570	3.8	
7-1/2		13	720002610	4.5	
8-1/2		13	720002622	5.0	
9		13	720002624	5.3	
10		13	720002625	5.9	
11		13	720002627	6.4	
5/8" (.625") 3/32" Key	7-1/2	11	720002990	7.0	10
	8-1/2	11	720003002	7.9	
	9	11	720003003	8.3	
	10	11	720003005	9.2	
	11	11	720003006	10.0	
	12	11	720003007	10.9	

NON-STANDARD LENGTHS - UNRC

DIAMETER	LENGTH UNDER HEAD	THREAD SERIES UNRC	PRODUCT CODE NUMBER	APPROX. WT. LBS. PER BOX	QTY IN BOX
3/4" (.750") 5/8" Key	7-1/2	10	720003350	10.4	10
	8-1/2	10	720003352	11.6	
	9	10	720003354	12.2	
	9-1/2	10	720003356	12.8	
	10	10	720003363	13.5	
	11	10	720003364	14.7	
	12	10	720003365	16.0	
	13	10	720003366	17.2	
1" (1.000") 3/4" Key	1-1/2	8	720003677	6.1	10
	1-3/4	8	720003678	6.6	
	3-3/4	8	720003810	10.8	
	7-1/2	8	720003950	19.0	
	8-1/2	8	720003962	21.2	
	9	8	720003964	22.4	
	9-1/2	8	720003966	23.5	
	10	8	720003984	24.6	
	11	8	720003985	26.8	
	12	8	720003986	29.0	
14	8	720003987	33.4		



Socket Head Cap Screws

HEAT TREATED ALLOY STEEL • UNIFIED 3A THREAD FIT
Meets ASME/ANSI B18.3 • Meets ASTM A574

NON-STANDARD LENGTHS - UNRF

DIAMETER	LENGTH UNDER HEAD	THREAD SERIES UNRF	PRODUCT CODE NUMBER	APPROX. WT. LBS. PER BOX	QTY IN BOX
#10 (.190") 5/32" Key	5/16	32	730000698	.6	100
	2-3/4	32	730000891	2.4	
5/16" (.312") 1/4" Key	3	24	730001440	6.9	100
	3-1/2	24	730001480	3.9	50
	4	24	730001490	4.5	
3/8" (.375") 5/16" Key	4-1/2	24	730001820	7.4	50
	5-1/2	24	730001840	9.2	
	6	24	730001850	9.5	
7/16" (.437") 3/8" Key	2-1/2	20	730002060	6.0	50
	3	20	730002080	3.5	25
	3-1/2	20	730002140	4.0	
1/2" (.500") 3/8" Key	3/4	20	730002220	4.2	50

NON-STANDARD LENGTHS - UNRF

DIAMETER	LENGTH UNDER HEAD	THREAD SERIES UNRF	PRODUCT CODE NUMBER	APPROX. WT. LBS. PER BOX	QTY IN BOX	
3/4" (.750") 5/8" Key	1-1/4	16	730003020	7.1	25	
	1-1/2	16	730003040	7.6		
	1-3/4	16	730003060	8.0		
	2	16	730003080	9.1		
	2-1/4	16	730003100	9.9		
	2-1/2	16	730003120	10.6		
	2-3/4	16	730003140	11.4		
	3	16	730003160	12.3		
	3-1/2	16	730003200	13.8		
	3-3/4	16	730003210	14.8		
	4	16	730003220	15.4		
	4-1/2	16	730003240	17.1		
	5	16	730003260	18.8		
	5-1/2	16	730003280	8.0		10
	6	16	730003300	8.7		
	7	16	730003340	10.0		
	8	16	730003360	11.2		



Socket Head Cap Screws Zinc and Clear Chromate -UNRC

DECORATIVE FLASH PLATE

Meets ASME/ANSI B18.3 and ASTM 574 Before Plate

DIAMETER	LENGTH UNDER HEAD	THREAD SERIES UNRC	PRODUCT CODE NUMBER	APPROX. WT. LBS. PER BOX	QTY IN BOX
#4 (.112") 3/32" Key	1/4"	40	ZP1C72018	.2	100
	3/8"	40	ZP1C72020	.2	
	1/2"	40	ZP1C72022	.3	
	5/8"	40	ZP1C72024	.3	
	3/4"	40	ZP1C72026	.3	
#5 (.125") 3/32" Key	1/4"	40	ZP1C72028	.2	100
	3/8"	40	ZP1C72030	.3	
	1/2"	40	ZP1C72032	.3	
	5/8"	40	ZP1C72034	.3	
#6 (.138") 7/64" Key	3/4"	40	ZP1C72036	.4	100
	1/4"	32	ZP1C72038	.3	
	3/8"	32	ZP1C72040	.3	
	1/2"	32	ZP1C72042	.4	
	5/8"	32	ZP1C72044	.4	
	3/4"	32	ZP1C72046	.4	
#8 (.164") 9/64" Key	7/8"	32	ZP1C72048	.5	100
	1"	32	ZP1C72050	.5	
	1/4"	32	ZP1C72052	.4	
	3/8"	32	ZP1C72054	.5	
	1/2"	32	ZP1C72056	.5	
	5/8"	32	ZP1C72058	.6	
	3/4"	32	ZP1C72060	.7	
	7/8"	32	ZP1C72062	.7	
#10 (.190") 5/32" Key	1"	32	ZP1C72064	.8	100
	1-1/4"	32	ZP1C72066	.9	
	1-1/2"	32	ZP1C72068	1.1	
	3/8"	24	ZP1C72070	.6	
	1/2"	24	ZP1C72072	.7	
	5/8"	24	ZP1C72074	.8	
	3/4"	24	ZP1C72076	.9	
	7/8"	24	ZP1C72078	.9	
1/4" (.250") 3/16" Key	1"	24	ZP1C72080	1.0	100
	1-1/4"	24	ZP1C72082	1.3	
	1-1/2"	24	ZP1C72084	1.4	
	1-3/4"	24	ZP1C72086	1.6	
	2"	24	ZP1C72088	1.9	
	1/4"	20	ZP1C86526	.8	
	3/8"	20	ZP1C72090	1.0	
	1/2"	20	ZP1C72092	1.2	
5/8"	20	ZP1C72094	1.3		
3/4"	20	ZP1C72096	1.5		
7/8"	20	ZP1C72098	1.6		
1"	20	ZP1C72100	1.8		
1-1/4"	20	ZP1C72102	2.1		
1-1/2"	20	ZP1C72104	2.5		

DIAMETER	LENGTH UNDER HEAD	THREAD SERIES UNRC	PRODUCT CODE NUMBER	APPROX. WT. LBS. PER BOX	QTY IN BOX
1/4" (.250") 3/16" Key	1-3/4"	20	ZP1C72106	2.9	100
	2"	20	ZP1C72108	3.0	
	2-1/2"	20	ZP1C72112	3.8	
	2-1/4"	20	ZP1C72110	3.4	
	2-3/4"	20	ZP1C72114	4.0	
	3"	20	ZP1C72116	4.3	
	3-1/2"	20	ZP1C72117	4.6	
5/16" (.312") 1/4" Key	4"	20	ZP1C72115	5.7	100
	3/8"	18	ZP1C72118	1.8	
	1/2"	18	ZP1C72120	2.0	
	5/8"	18	ZP1C72122	2.3	
	3/4"	18	ZP1C72124	2.5	
	7/8"	18	ZP1C72126	2.7	
	1"	18	ZP1C72128	2.9	
	1-1/4"	18	ZP1C72130	3.4	
	1-1/2"	18	ZP1C72132	3.9	
	1-3/4"	18	ZP1C72134	4.4	
	2"	18	ZP1C72136	4.9	
	2-1/4"	18	ZP1C72138	5.4	
	2-1/2"	18	ZP1C72140	5.9	
	2-3/4"	18	ZP1C72142	6.4	
3"	18	ZP1C72144	6.9		
3-1/4"	18	ZP1C72146	3.7	50	
3-1/2"	18	ZP1C72148	3.9		
3/8" (.375") 5/16" Key	1/2"	16	ZP1C72150	3.4	100
	5/8"	16	ZP1C72152	3.8	
	3/4"	16	ZP1C72154	4.0	
	7/8"	16	ZP1C72156	4.3	
	1"	16	ZP1C72158	4.6	
	1-1/4"	16	ZP1C72160	5.2	
	1-1/2"	16	ZP1C82162	6.0	
	1-3/4"	16	ZP1C72164	3.3	50
	2"	16	ZP1C72166	3.9	
	2-1/4"	16	ZP1C72168	4.3	
	2-1/2"	16	ZP1C72170	4.5	
	2-3/4"	16	ZP1C72172	4.9	
	3"	16	ZP1C72174	5.1	
	3-1/4"	16	ZP1C72176	5.3	
	3-1/2"	16	ZP1C72178	5.8	
	4"	16	ZP1C72180	6.6	
4-1/2"	16	ZP1C72182	7.4		
5"	16	ZP1C72184	7.6		
5-1/2"	16	ZP1C86688	9.2		
6"	16	ZP1C72185	9.4		



Socket Head Cap Screws

Zinc and Clear Chromate -UNRC

DECORATIVE FLASH PLATE
Meets ASME/ANSI B18.3 and ASTM 574 Before Plate

DIAMETER	LENGTH UNDER HEAD	THREAD SERIES UNRC	PRODUCT CODE NUMBER	APPROX. WT. LBS. PER BOX	QTY IN BOX
7/16" (.437") 3/8" Key	3/4"	14	ZP1C72190	5.6	100
	7/8"	14	ZP1C72192	6.0	
	1"	14	ZP1C72194	6.4	
	1-1/4"	14	ZP1C72196	3.8	50
	1-1/2"	14	ZP1C72198	4.2	
	1-3/4"	14	ZP1C72200	4.6	
	2"	14	ZP1C72202	5.0	
	2-1/4"	14	ZP1C72204	5.5	
	2-1/2"	14	ZP1C72206	6.0	25
	2-3/4"	14	ZP1C72208	3.3	
3"	14	ZP1C72210	3.5		
3-1/2"	14	ZP1C72214	4.0		
4"	14	ZP1C72216	4.5		
1/2" (.500") 3/8" Key	1/2"	13	ZP1C72218	3.7	50
	5/8"	13	ZP1C72220	4.0	
	3/4"	13	ZP1C72222	4.2	
	7/8"	13	ZP1C72224	4.5	
	1"	13	ZP1C72226	4.8	
	1-1/4"	13	ZP1C72228	5.3	
	1-1/2"	13	ZP1C72230	6.3	
	1-3/4"	13	ZP1C72232	6.6	
	2"	13	ZP1C72234	7.4	25
	2-1/4"	13	ZP1C72236	4.0	
	2-1/2"	13	ZP1C72238	4.4	
	2-3/4"	13	ZP1C72240	4.6	
	3"	13	ZP1C72242	4.9	
	3-1/4"	13	ZP1C72244	5.1	
	3-1/2"	13	ZP1C72246	6.0	
	4"	13	ZP1C72248	6.3	
	4-1/2"	13	ZP1C72250	7.0	
	5"	13	ZP1C72252	7.9	
	5-1/2"	13	ZP1C72254	8.6	10
	6"	13	ZP1C72256	9.3	
6-1/2"	13	ZP1C72258	3.8		
7"	13	ZP1C72260	4.0		
8"	13	ZP1C72262	4.5		

DIAMETER	LENGTH UNDER HEAD	THREAD SERIES UNRC	PRODUCT CODE NUMBER	APPROX. WT. LBS. PER BOX	QTY IN BOX
5/8" (.625") 1/2" Key	1"	11	ZP1C72264	4.3	25
	1-1/4"	11	ZP1C72266	4.8	
	1-1/2"	11	ZP1C72268	5.3	
	1-3/4"	11	ZP1C72270	5.6	
	2"	11	ZP1C72272	6.0	
	2-1/4"	11	ZP1C72274	6.8	
	2-1/2"	11	ZP1C72276	7.3	
	2-3/4"	11	ZP1C72278	7.8	
	3"	11	ZP1C72280	8.4	
	3-1/4"	11	ZP1C72282	9.0	
	3-1/2"	11	ZP1C72284	9.5	10
	4"	11	ZP1C72286	10.5	
	4-1/2"	11	ZP1C72288	9.5	
	5"	11	ZP1C72290	10.5	
	5-1/2"	11	ZP1C72292	5.3	
	6"	11	ZP1C72294	5.5	
	6-1/2"	11	ZP1C72296	5.9	
7"	11	ZP1C72298	6.3		
8"	11	ZP1C72300	7.0		
3/4" (.750") 5/8" Key	1-1/4"	10	ZP1C72302	7.1	25
	1-1/2"	10	ZP1C72304	7.6	
	1-3/4"	10	ZP1C72306	8.4	
	2"	10	ZP1C72308	9.1	
	2-1/4"	10	ZP1C72310	9.9	
	2-1/2"	10	ZP1C72312	10.6	
	2-3/4"	10	ZP1C72314	11.4	
	3"	10	ZP1C72316	12.3	
	3-1/4"	10	ZP1C72318	13.0	20
	3-1/2"	10	ZP1C72320	13.8	
	4"	10	ZP1C72322	15.4	
	4-1/2"	10	ZP1C72324	14.0	
	5"	10	ZP1C72326	14.7	
5-1/2"	10	ZP1C72328	7.9	10	
6"	10	ZP1C72330	8.4		
6-1/2"	10	ZP1C72332	9.0		
7"	10	ZP1C72334	9.6		
8"	10	ZP1C72336	10.8		

PLEASE ORDER BY PRODUCT CODE NUMBER



Socket Head Cap Screws Zinc and Clear Chromate-UNRC

DECORATIVE FLASH PLATE

Meets ASME/ANSI B18.3 and ASTM A 574 Before Plate

DIAMETER	LENGTH UNDER HEAD	THREAD SERIES UNRC	PRODUCT CODE NUMBER	APPROX. WT. LBS. PER BOX	QTY IN BOX
7/8" (.875") 3/4" Key	2"	9	ZP1C72338	5.1	10
	2-1/2"	9	ZP1C72342	5.8	
	3"	9	ZP1C72346	6.6	
	3-1/2"	9	ZP1C72350	7.6	
	4"	9	ZP1C72352	8.4	
	4-1/2"	9	ZP1C72354	9.2	
	5"	9	ZP1C72356	10.0	
	6"	9	ZP1C72360	11.6	
	7"	9	ZP1C72364	13.0	
8"	9	ZP1C72366	13.6		

DIAMETER	LENGTH UNDER HEAD	THREAD SERIES UNRC	PRODUCT CODE NUMBER	APPROX. WT. LBS. PER BOX	QTY IN BOX
1" (1.000") 3/4" Key	2"	8	ZP1C72368	7.1	10
	2-1/2"	8	ZP1C72372	8.1	
	3"	8	ZP1C72376	9.2	
	3-1/2"	8	ZP1C72380	10.3	
	4"	8	ZP1C72382	11.3	
	4-1/2"	8	ZP1C72384	12.4	
	5"	8	ZP1C72386	13.5	
	6"	8	ZP1C72390	15.8	
	7"	8	ZP1C72394	17.8	
8"	8	ZP1C72396	19.8		



Socket Head Cap Screws Zinc and Clear Chromate-UNRF

DECORATIVE FLASH PLATE

Meets ASME/ANSI B18.3 and ASTM A 574 Before Plate

DIAMETER	LENGTH UNDER HEAD	THREAD SERIES UNRF	PRODUCT CODE NUMBER	APPROX. WT. LBS. PER BOX	QTY IN BOX
#10 (.190") 5/32" Key	1/4"	32	ZP1C77388	.5	100
	3/8"	32	ZP1C73034	.6	
	1/2"	32	ZP1C73036	.7	
	5/8"	32	ZP1C73038	.8	
	3/4"	32	ZP1C73040	.9	
	7/8"	32	ZP1C73042	.9	
	1"	32	ZP1C73044	1.0	
	1-1/4"	32	ZP1C73046	1.3	
	1-1/2"	32	ZP1C73048	1.4	
	1-3/4"	32	ZP1C73050	1.6	
2"	32	ZP1C73052	2		
1/4" (.250") 3/16" Key	3/8"	28	ZP1C73054	1.0	100
	1/2"	28	ZP1C73056	1.2	
	5/8"	28	ZP1C73058	1.4	
	3/4"	28	ZP1C73060	1.5	
	7/8"	28	ZP1C73062	1.6	
	1"	28	ZP1C73064	1.8	
	1-1/4"	28	ZP1C73066	2.1	
	1-1/2"	28	ZP1C73068	2.5	
	1-3/4"	28	ZP1C73070	2.8	
	2"	28	ZP1C73072	3.0	
2-1/4"	28	ZP1C73074	3.4		

DIAMETER	LENGTH UNDER HEAD	THREAD SERIES UNRF	PRODUCT CODE NUMBER	APPROX. WT. LBS. PER BOX	QTY IN BOX
5/16" (.312") 1/4" Key	1/2"	24	ZP1C73076	2.0	100
	5/8"	24	ZP1C73078	2.3	
	3/4"	24	ZP1C73080	2.5	
	7/8"	24	ZP1C73082	2.7	
	1"	24	ZP1C73084	2.9	
	1-1/4"	24	ZP1C73086	3.4	
	1-1/2"	24	ZP1C73088	3.9	
	1-3/4"	24	ZP1C73090	4.4	
	2"	24	ZP1C73092	4.9	
	2-1/4"	24	ZP1C73094	5.4	
	2-1/2"	24	ZP1C73096	5.9	



Socket Head Cap Screws

Zinc and Clear Chromate-UNRF

DECORATIVE FLASH PLATE

Meets ASME/ANSI B18.3 and ASTM A 574 Before Plate

DIAMETER	LENGTH UNDER HEAD	THREAD SERIES UNRF	PRODUCT CODE NUMBER	APPROX. WT. LBS. PER BOX	QTY IN BOX
3/8" (.375") 5/16" Key	1/2"	24	ZP1C73098	3.4	100
	5/8"	24	ZP1C73100	3.8	
	3/4"	24	ZP1C73102	4.0	
	7/8"	24	ZP1C73104	4.3	
	1"	24	ZP1C73106	4.6	
	1-1/4"	24	ZP1C73108	5.2	
	1-1/2"	24	ZP1C73110	6.0	50
	1-3/4"	24	ZP1C73112	3.3	
	2	24	ZP1C73114	3.9	
	2-1/4"	24	ZP1C73116	4.3	
7/16" (.437") 3/8" Key	2-1/2"	24	ZP1C73118	4.5	50
	3"	24	ZP1C73120	5.1	
	1"	20	ZP1C73122	6.4	100
	1-1/4"	20	ZP1C73124	3.8	50
	1-1/2"	20	ZP1C73126	4.2	
2"	20	ZP1C73128	5.0		

DIAMETER	LENGTH UNDER HEAD	THREAD SERIES UNRF	PRODUCT CODE NUMBER	APPROX. WT. LBS. PER BOX	QTY IN BOX
1/2" (.500") 3/8" Key	1"	20	ZP1C73130	4.8	50
	1-1/4"	20	ZP1C73132	5.3	
	1-1/2"	20	ZP1C73134	6.3	
	1-3/4"	20	ZP1C73136	6.6	
	2"	20	ZP1C73138	7.4	
	2-1/4"	20	ZP1C73140	4.0	
	2-1/2"	20	ZP1C73142	4.4	
	2-3/4"	20	ZP1C73143	4.6	
	3"	20	ZP1C73144	4.8	
	5/8" (.625") 3/32" Key	1"	18	ZP1C73146	4.3
1-1/4"		18	ZP1C73148	4.8	
1-1/2"		18	ZP1C73150	5.3	
1-3/4"		18	ZP1C73152	5.6	
2"		18	ZP1C73154	6.0	
2-1/2"		18	ZP1C73156	7.3	



Socket Head Cap Screws- Zinc Plated

Heat Treated Alloy Steel • ISO Metric Threads • Grade 12.9

Specifications: Dimensions: ISO 4762,BS4168.1

Mechanical Properties: ISO 898.1

Decorative Flash Zinc Plate and Clear Chromate

DIAMETER	LENGTH UNDER HEAD	PRODUCT CODE NUMBER	APPROX. WT. LBS. PER BOX	QTY IN BOX
M3 Pitch .50 2.5mm Key	6	ZP1C76008	.2	100
	8	ZP1C76012	.4	
	10	ZP1C76016	.4	
	12	ZP1C76020	.4	
	15	ZP1C76026	.4	
	16	ZP1C76028	.4	
	20	ZP1C76032	.6	
	25	ZP1C76036	.6	
	30	ZP1C76040	.8	
	35	ZP1C76044	1.0	
M4 Pitch .70 3mm Key	6	ZP1C76052	.6	100
	8	ZP1C76056	.6	
	10	ZP1C76060	.8	
	12	ZP1C76064	.8	
	16	ZP1C76072	1.0	
	20	ZP1C76076	1.2	
	25	ZP1C76080	1.4	
	30	ZP1C76084	1.6	
	35	ZP1C76088	1.8	
M5 Pitch .80 4mm Key	8	ZP1C76104	1.0	100
	10	ZP1C76108	1.2	
	12	ZP1C76112	1.2	
	16	ZP1C76120	1.4	
	20	ZP1C76124	1.4	
	25	ZP1C76128	1.8	
	30	ZP1C76132	2.0	
	35	ZP1C76136	2.8	
	40	ZP1C76140	3.0	
M6 Pitch 1.00 5mm Key	45	ZP1C76144	3.4	100
	50	ZP1C76148	3.8	
	70	ZP1C76147	6.0	
	8	ZP1C76152	1.8	
	10	ZP1C76156	2.0	
	12	ZP1C76160	2.0	
	16	ZP1C76168	2.0	
	20	ZP1C76172	2.8	
	25	ZP1C76176	3.2	
30	ZP1C76180	3.8		
35	ZP1C76184	4.0		
40	ZP1C 76188	4.8		
45	ZP1C76192	5.2		
50	ZP1C76196	5.8		
55	ZP1C76200	6.0		
60	ZP1C76204	6.0		
70	ZP1C76212	7.6		

DIAMETER	LENGTH UNDER HEAD	PRODUCT CODE NUMBER	APPROX. WT. LBS. PER BOX	QTY IN BOX
M8 Pitch 1.25 6mm Key	10	ZP1C76220	4.4	100
	12	ZP1C76224	4.8	
	16	ZP1C76232	5.2	
	20	ZP1C76236	5.8	
	25	ZP1C76240	6.6	
	30	ZP1C76244	7.4	
	35	ZP1C76248	8.0	
	40	ZP1C76252	9.2	
	45	ZP1C76256	10.0	
	50	ZP1C76260	11.0	
	55	ZP1C76264	11.8	
	60	ZP1C76268	12.0	
	65	ZP1C76272	13.6	
	70	ZP1C76276	14.0	
M10 Pitch 1.50 8mm Key	12	ZP1C76284	8.0	100
	16	ZP1C76292	9.2	
	20	ZP1C76296	10.0	
	25	ZP1C76300	5.7	
	30	ZP1C76304	6.1	
	35	ZP1C76308	6.8	
	40	ZP1C76312	7.5	
	45	ZP1C76316	8.0	
	50	ZP1C76320	8.8	
	55	ZP1C76324	9.6	
	60	ZP1C76328	5.1	
	65	ZP1C76332	5.4	
	70	CP1C76336	5.8	
	75	ZP1C76340	6.1	
80	ZP1C76344	6.4		
M12 Pitch 1.75 10mm Key	20	ZP1C76356	7.0	100
	25	ZP1C76360	7.8	
	30	ZP1C76364	8.6	
	35	ZP1C76368	9.4	
	40	ZP1C76372	5.2	
	45	ZP1C76376	5.7	
	50	ZP1C76380	6.1	
	55	ZP1C76384	6.6	
	60	ZP1C76388	7.1	
	65	ZP1C76392	7.6	
	70	ZP1C76396	8.1	
	75	ZP1C76400	8.6	
	80	ZP1C76404	9.0	
	90	ZP1C76408	5.0	
100	ZP1C76412	5.5		
110	ZP1C76416	6.0		
120	ZP1C76420	6.4		

Socket Head Cap Screws- Zinc Plated

Heat Treated Alloy Steel • ISO Metric Threads • Grade 12.9

Specifications: Dimensions: ISO 4762, BS4168.1

Mechanical Properties: ISO 898.1

Decorative Flash Zinc Plate and Clear Chromate



DIAMETER	LENGTH UNDER HEAD	PITCH	PRODUCT CODE NUMBER	APPROX. WT. LBS. PER BOX	QTY IN BOX
M16 Pitch 2.00 14mm Key	30	2.00	ZP1C76424	4.2	25
	35	2.00	ZP1C76428	4.8	
	40	2.00	ZP1C76432	5.0	
	45	2.00	ZP1C76436	5.3	
	50	2.00	ZP1C76440	5.8	
	55	2.00	ZP1C76444	6.2	
	60	2.00	ZP1C76448	6.7	
	65	2.00	ZP1C76452	7.1	
	70	2.00	ZP1C76456	7.5	
	75	2.00	ZP1C76460	8.0	
	80	2.00	ZP1C76464	8.5	
	90	2.00	ZP1C76468	9.3	
	100	2.00	ZP1C76472	4.0	10
	110	2.00	ZP1C76476	4.4	
	120	2.00	ZP1C76480	4.7	



Socket Head Cap Screws Non-Heat Treated Stainless Steel

ISO 3506-1 A2-70

ASTM F837M A1-70

DIAMETER	LENGTH UNDER HEAD	PRODUCT CODE NUMBER	APPROX. WT. LBS. PER BOX	QTY IN BOX
M3 Pitch .50 2.5mm Key	6	77004	.2	100
	8	77008	.2	
	10	77012	.2	
	12	77016	.2	
	16	77020	.4	
M4 Pitch .70 3mm Key	8	77044	.4	100
	10	77048	.4	
	12	77052	.5	
	16	77056	.6	
	20	77060	.6	
	25	77064	.8	
	30	77068	.9	
32	77070	1.0		

DIAMETER	LENGTH UNDER HEAD	PRODUCT CODE NUMBER	APPROX. WT. LBS. PER BOX	QTY IN BOX
M5 Pitch .80 4mm Key	10	77084	.7	100
	12	77088	.8	
	16	77092	1.0	
	20	77096	1.0	
	22	77098	1.0	
	25	77100	1.1	
	30	77104	1.3	
	35	77108	1.5	
M6 Pitch 1.00 5mm Key	40	77110	1.6	100
	12	77124	1.2	
	16	77128	1.3	
	20	77132	1.5	
	22	77134	1.6	
	25	77136	1.7	
30	77140	1.9		

PLEASE ORDER BY PRODUCT CODE NUMBER



Socket Set Screws Stainless Steel - Cup Point

NON-HEAT TREATED
Meets ANSI/ASME B18.3

DIAMETER	LENGTH	THREAD SERIES UNC	PRODUCT CODE NUMBER	APPROX. WT. LBS. PER BOX	QTY IN BOX
#6 (.138") 1/16" Key	3/8"	32	520000580	.1	100
	1/2"	32	520000600	.2	
#10 (.190") 3/32" Key	3/16"	24	520000920	.1	100
	1/2"	24	520001000	.3	
1/4" (.250") 1/8" Key	5/8"	20	520001220	.6	100
3/8" (.375") 3/16" Key	5/8"	16	520001740	1.3	100

DIAMETER	LENGTH	THREAD SERIES UNF	PRODUCT CODE NUMBER	APPROX. WT. LBS. PER BOX	QTY IN BOX
#10 (.190") 3/32" Key	5/16"	32	530000960	.3	100
	1/4" (.250") 1/8" Key	28	530001140	.3	100

DIAMETER	LENGTH	THREAD SERIES UNC	PRODUCT CODE NUMBER	APPROX. WT. LBS. PER BOX	QTY IN BOX
#4 (.112") 3/32" Key	3/16"	40	PATCH52020	.1	100
	1/4"	40	PATCH52022	.1	
#6 (.138") 7/64" Key	3/16"	32	PATCH52026	.1	100
	1/4"	32	PATCH52028	.1	
	3/8"	32	PATCH520000580	.1	
	1/2"	32	PATCH520000600	.2	
#8 (.164") 9/64" Key	3/16"	32	PATCH52036	.1	100
	1/4"	32	PATCH52038	.1	
	5/16"	32	PATCH52040	.2	
	3/8"	32	PATCH52042	.2	
	1/2"	32	PATCH52044	.2	
#10 (.190") 5/32" Key	3/16"	24	PATCH520000920	.1	100
	1/4"	24	PATCH52048	.1	
	3/8"	24	PATCH52052	.3	
	1/2"	24	PATCH520001000	.3	
1/4" (.250") 3/16" Key	1/4"	20	PATCH52062	.3	100
	5/16"	20	PATCH52064	.3	
	3/8"	20	PATCH52066	.4	
	1/2"	20	PATCH52068	.5	
	5/8"	20	PATCH520001220	.6	
	3/4"	20	PATCH52072	.8	
	5/16" (.312") 1/4" Key	5/16"	18	PATCH52078	
3/8"	18	PATCH52080	.5		
1/2"	18	PATCH52082	.8		
3/8" (.375") 5/16" Key	3/8"	16	PATCH52088	.9	100
	1/2"	16	PATCH52090	1.1	
	5/8"	16	PATCH52001740	1.3	
	3/4"	16	PATCH52092	1.8	

Socket Set Screws Stainless Steel Cup Point w/Nylon Patch

NON-HEAT TREATED
UNIFIED 3A THREAD FIT
Meets ANSI/ASME B18.3

DIAMETER	LENGTH	THREAD SERIES UNF	PRODUCT CODE NUMBER	APPROX. WT. LBS. PER BOX	QTY IN BOX
#10 (.190") 5/32" Key	3/16"	32	PATCH53022	.1	100
	1/4"	32	PATCH53024	.1	
	5/16"	32	PATCH530000960	.2	
	3/8"	32	PATCH53028	.3	
	1/2"	32	PATCH53030	.3	
	5/8"	32	PATCH53032	.3	
	1/4" (.250") 3/16" Key	1/4"	28	PATCH530001140	

Socket Set Screws

Metric Series • Holo-Knurl® Point

HEAT TREATED ALLOY STEEL TO 45-53 HRC

ISO Metric Threads to ASME/ANSI B18.3.6M • ASME/ANSI B18.13M • Meets ASTM F912M



DIAMETER	LENGTH OVERALL	PRODUCT CODE NUMBER	APPROX. WT. LBS. PER BOX	QTY IN BOX
M3 Pitch .50 2.5mm Key	3	480000045	.1	100
	4	480000085	.2	
	5	480000125	.2	
	6	480000165	.2	
M4 Pitch .70 3mm Key	4	480000325	.2	100
	5	480000365	.2	
	6	480000405	.2	
	8	480000445	.2	
M5 Pitch .80 4mm Key	5	480000725	.2	100
	6	480000765	.2	
	8	480000805	.2	
	10	480000845	.2	
M6 Pitch 1.00 5mm Key	6	480001085	.4	100
	8	480001125	.4	
	10	480001165	.6	
	12	480001205	.8	
M8 Pitch 1.25 6mm Key	8	480001525	.8	100
	10	480001565	1.0	
	12	480001605	1.2	
	16	480001685	1.8	

PLEASE ORDER BY PRODUCT CODE NUMBER

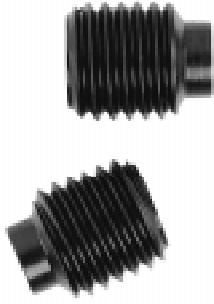

Socket Set Screws Half-Dog

ALLOY STEEL HEAT TREATED TO 45/53 HRC
Meets ANSI/ASME B18.3

DIAMETER	LENGTH	THREAD SERIES UNC	PRODUCT CODE NUMBER	APPROX. WT. LBS. PER BOX	QTY IN BOX
5/16" (.312") 5/32" Key	5/8"	18	200001480	.4	100



Socket Set Screws Half-Dog w/Nylon Patch

ALLOY STEEL HEAT TREATED TO 45/53 HRC
Meets ANSI/ASME B18.3

DIAMETER	LENGTH	THREAD SERIES UNC	PRODUCT CODE NUMBER	APPROX. WT. LBS. PER BOX	QTY IN BOX
#8 (.164") 9/64" Key	1/4"	32	PATCH20004	.1	100
#10 (.190") 5/32" Key	1/4"	24	PATCH20014	.1	100
1/4" (.250") 3/16" Key	5/16"	20	PATCH20024	.3	100
	3/8"	20	PATCH20026	.4	
	1/2"	20	PATCH20028	.5	
	5/8"	20	PATCH20030	.7	
5/16" (.312") 1/4" Key	3/8"	18	PATCH20038	.5	100
	5/8"	18	PATCH200001480	1.1	
	3/4"	18	PATCH20044	1.2	
3/8" (.375") 5/16" Key	1/2"	16	PATCH20050	1.1	100
	5/8"	16	PATCH20052	1.5	
	3/4"	16	PATCH20054	1.8	
	1"	16	PATCH20056	2.5	

INCH AND METRIC Assortments Set Screw and Key Assortments

Precision tolerances, heat treated alloy steel, black finish

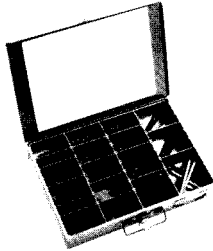

Item No.
56880
SET
NUMBER
602

Set Screw and Hex Key Assortment

An assortment of 11 popular sizes of socket set screws (cup point) with keys to fit. Contains 590 set screws in varying sizes and 115 hex keys. Size of box: 9-3/4" x 12-1/2". Weight: 9.5 lb. unit packaged.

Assortment Contents

SET SCREW SIZE, IN.	STANDARD PACK	SET SCREW SIZE, IN.	STANDARD PACK	KEY SIZE, IN.	STANDARD PACK
#10-32 x 3/16	100	3/8-16 x 3/8	50	3/32	25
#10-32 x 1/4	50	3/8-16 x 1/2		1/8	
1/4-20 x 1/4	100	7/16-14 x 7/16	20	5/32	
1/4-20 x 3/8	50	1/2-13 x 1/2		3/16	
5/16-18 x 5/16	100	5/8-11 x 5/8	10	7/32	5
5/16-18 x 3/8	50			5/16	

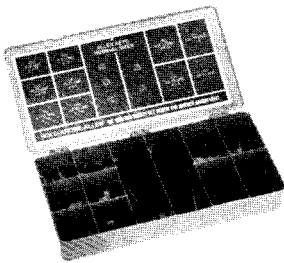

Item No.
56884
SET
NUMBER
608

Set Screw and Hex Key Assortment

An assortment of 10 popular sizes of socket set screws (cup point) with keys to fit. Contains 100 set screws in varying sizes and 45 hex keys. Size of box: 7-3/4" x 6-1/2" x 1-1/4". Weight: 1.3 lb. unit packaged.

Assortment Contents

SET SCREW SIZE, IN.	STANDARD PACK	SET SCREW SIZE, IN.	STANDARD PACK	KEY SIZE, IN.	STANDARD PACK
#8-32 x 3/16		1/4-20 x 3/8		5/64	
#8-32 x 1/4		5/16-18 x 5/16		3/32	10
#10-32 x 3/16	10	5/16-18 x 3/8	10	1/8	
#10-32 x 1/4		3/8-16 x 3/8		5/32	
1/4-20 x 1/4		3/8-16 x 1/2		3/16	5

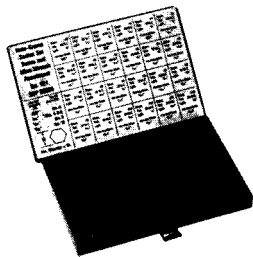

Item No.
56886
SET
NUMBER
621

"Handi-Kit" Set Screw and Hex Key Assortment

A handy, compact assortment of numbered size socket set screws with keys to fit. Contains 288 screws (cup point, coarse thread series) in varying sizes and 48 keys. Size of box: 8" x 5-1/4" x 5/8". Weight: 1.3 lb unit packaged.

Assortment Contents

SET SCREW SIZE, IN.	SET SCREW SIZE, IN.	SET SCREW SIZE, IN.	SET SCREW SIZE, IN.	SET SCREW SIZE, IN.	STANDARD PACK	SET SCREW SIZE, IN.	STANDARD PACK	KEY SIZE, IN.	STANDARD PACK
#4-40 X 1/8	#4-40 X 5/16	#5-40 X 3/16	#5-40 X 3/8	#6-32 x 1/4		#8-32 x 5/16		.050	
#4-40 X 3/16	#4-40 X 3/8	#5-40 X 1/4	#6-32 X 1/8	#6-32 x 5/16		#8-32 x 3/8		1/16	
#40-40 X 1/4	#5-40 X 1/8	#5-40 X 5/16	#6-32 X 3/16	#6-32 x 3/8	12	#10-24 x 3/16	12	5/64	12
				#8-32 x 1/8		#10-24 x 1/4		3/32	
				#8-32 x 3/16		#10-24 x 5/16			
				#8-32 x 1/4		#10-24 x 3/8			

PLEASE ORDER BY PRODUCT CODE NUMBER

METRIC ASSORTMENTS

Cap Screw, Set Screw and Key Assortment

Precision tolerances, heat treated alloy steel, black finish

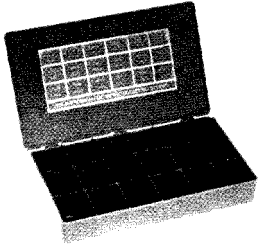

Item No.

48390

SET
NUMBER

MK1

Metric Set Screw and Hex Key Assortment

An assortment of 18 popular sizes of metric socket set screws (cup point) and 4 Allen hex keys. Contains 270 set screws in varying sizes. Size of box: 11" x 6-3/4" x 1-3/4". Weight: 1.5 lbs. unit packaged.

Assortment Contents

SET SCREW SIZE, MM	STANDARD PACK	SET SCREW SIZE, MM	STANDARD PACK	KEY SIZE, MM	STD PACK
M4 x 6	25	M6 x 8	25	2	1
M4 x 8		M6 x 10		2.5	
M4 x 10	10	M6 x 12	10	3	
M4 x 12		M6 x 20		4	
M5 x 6	25	M8 x 8		10	
M5 x 8		M8 x 10			
M5 x 10	10	M8 x 12	10		
M5 x 12		M8 x 20			
M6 x 6	25	M8 x 25			

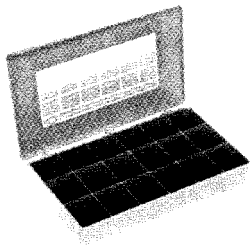

Item No.

76582

SET
NUMBER

MK2

Metric Socket Head Cap Screw and Hex Key Assortment

An assortment of 18 popular sizes of metric socket head cap screws and 4 Allen hex keys. Contains 270 set screws in varying sizes. Size of box: 11" x 6-3/4" x 1-3/4". Weight: 5 lbs. unit packaged.

Assortment Contents

SET SCREW SIZE, MM	STANDARD PACK	SET SCREW SIZE, MM	STANDARD PACK	KEY SIZE, MM	STD PACK
M4 x 10	25	M6 x 20	10	3	1
M4 x 12		M6 x 25		4	
M4 x 20		M6 x 30		5	
M4 x 25		M6 x 40		6	
M5 x 12	25	M8 x 20	10		
M5 x 20		M8 x 25			
M5 x 25	10	M8 x 30		10	
M5 x 30		M8 x 40			
M6 x 12		M8 x 45			

Dimension Standards

Precision tolerances, heat treated alloy steel, black finish

Allen Hex Key Fit Selector - Keys Fit These Products

NOMINAL KEY SIZE, INCHES	SOCKET HEAD CAP SCREWS		FLAT HEAD CAP SCREWS	BUTTON HEAD CAP SCREWS	SET SCREWS	SHOULDER SCREWS	PRESSURE PLUGS	ALLENUTS	LOW HEAD CAPSCREWS	NOMINAL KEY SIZE, INCH
	1960 SERIES	1936 SERIES								
.028	-	-	-	-	0	-	-	-	-	.028
.035	-	-	0	0	1,2	-	-	-	-	.035
.050	0	0,1	1,3	1,3	3,4	-	-	-	4	.050
1/16	1	2	3,4	3,4	5,6	-	-	-	5,6	1/16
5/64	2,3	3,4	5,6	5,6	8	-	-	-	8	5/64
3/32	4,5	5,6	8	8	10	-	-	-	10	3/32
7/64	6	-	-	-	-	-	-	-	-	7/64
1/8	-	8	10	10	1/4	1/4	-	4,5	1/4	1/8
9/64	8	10	-	-	-	-	-	-	-	9/64
5/32	10	1/4	1/4	1/4	5/16	5/16	1/16	6	5/16	5/32
3/16	1/4	-	5/16	5/16	3/8	3/8	1/8	8,10	3/8	3/16
7/32	-	5/16	3/8	3/8	7/16	-	-	-	7/16	7/32
1/4	5/16	-	7/16	-	1/2	1/2	1/4	1/4	1/2	1/4
5/16	3/8	3/8, 7/16	1/2	-	5/8	5/8	3/8	5/16	5/8	5/16
3/8	7/16, 1/2	1/2	5/8	-	3/4	3/4	1/2	3/8	-	3/8
7/16	-	-	-	-	-	-	-	7/16	-	7/16
1/2	5/8	5/8	3/4	-	7/8	1	-	1/2	-	1/2
9/16	-	3/4, 7/8	7/8	-	1, 1-1/8	-	3/4	-	-	9/16
5/8	3/4	1	1	-	1-1/4, 1-3/8	1-1/4	1	5/8	-	5/8
3/4	7/8, 1	-	1-1/8	-	1-1/2	-	1-1/4	3/4	-	3/4
7/8	1-1/8, 1-1/4	-	1-1/4, 1-3/8	-	-	1-1/2	-	7/8	-	7/8
1	1-3/8, 1-1/2	1-1/2	1-1/2	-	1-3/4, 2	1-3/4	1-1/2, 2	1	-	1
1-1/4	1-3/4	-	-	-	-	2	-	1-1/4	-	1-1/4
1-1/2	2	1-1/8, 1-1/4, 1-3/8	-	-	-	-	-	1-1/2	-	1-1/2
1-3/4	2-1/4, 2-1/2	-	-	-	-	-	-	-	-	1-3/4
2	-3/4	-	-	-	-	-	-	-	-	2

Allen Hex Key Fit Selector - Keys Fit These Products

NOMINAL KEY SIZE, MM	SOCKET HEAD CAP SCREWS	FLAT HEAD CAP SCREWS	BUTTON HEAD CAP SCREWS	SET SCREWS	SHOULDER SCREWS	ALLENUTS	LOW HEAD CAP SCREWS	NOMINAL KEY SIZE, MM
0.7	-	-	-	M1.4,M1.6,M1.7	-	-	-	0.7
0.9	-	-	-	M2,M2.3	-	-	-	0.9
1.3	M1.4	-	-	M2.5, M2.6	-	-	-	1.3
1.5	M1.6, M1.7, M2	-	-	M3	-	-	-	1.5
2	M2.3, M2.5, M2.6	M3	M3	M4	-	-	-	2
2.5	M3	M4	M4	M5	-	-	-	2.5
3	M4	M5	M5	M6	6mm	M3	M4	3
4	M5	M6	M6	M8	8mm	M4	M5	4
5	M6	M8	M8	M10	10mm	M6	M6	5
6	M8	M10	M10	M12, M14	12mm	M6	M8	6
8	M10	M12	M12	M16	16mm	M8	M10	8
10	M12	M14, M16	-	M20	20mm	M10	M12	10
12	M14	M20	-	M24	-	M12	M14	12
14	M16	-	-	-	-	-	M16	14
17	M20	-	-	-	-	M16	M20, M22	17
19	M24	-	-	-	-	-	M24	19

PLEASE ORDER BY PRODUCT CODE NUMBER

Dimension Standards

Precision tolerances, heat treated alloy steel, black finish

Inch Keys & Bits

NOMINAL KEY AND SOCKET SIZE IN.	W		Y		B		C				R	K
	HEXAGON WIDTH ACROSS FLATS		HEXAGON WIDTH ACROSS CORNERS		LENGTH OF SHORT ARM		LENGTH OF LONG ARM, IN.				RADIUS OF BEND IN.	CHAMFER IN.
	IN.		IN.		IN.		SHORT SERIES		LONG SERIES			
	MAX.	MIN.	MAX.	MIN.	MAX.	MIN.	MAX.	MIN.	MAX.	MIN.	MIN.	MAX.
0.028	0.0280	0.0275	0.0314	0.0300	0.312	0.125	1.312	1.125	2.688	2.500	0.062	0.003
0.035	0.0350	0.0345	0.0393	0.0378	0.438	0.250	1.312	1.125	2.766	2.578	0.062	0.004
0.050	0.0500	0.0490	0.0560	0.0540	0.625	0.438	1.760	1.562	2.938	2.750	0.062	0.0006
1/16 0.062	0.0625	0.0615	0.0701	0.0680	0.656	0.469	1.844	1.656	3.094	2.906	0.062	0.008
5/64 0.078	0.0781	0.0771	0.0880	0.0859	0.703	0.516	1.969	1.781	3.281	3.094	0.078	0.008
3/32 0.094	0.0937	0.0927	0.1058	0.1035	0.750	0.562	2.094	1.906	3.469	3.281	0.094	0.009
7/64 0.109	0.1094	0.1079	0.1238	0.1210	0.797	0.609	2.219	2.031	3.656	3.469	0.109	0.014
1/8 0.125	0.1250	0.1235	0.1418	0.1390	0.844	0.656	2.344	2.156	3.844	3.656	0.125	0.015
9/64 0.141	0.1406	0.1391	0.1593	0.1566	0.891	0.703	2.469	2.281	4.031	3.844	0.141	0.016
5/32 0.156	0.1562	0.1547	0.1774	0.1745	0.938	0.750	2.594	2.406	4.219	4.031	0.156	0.016
3/16 0.188	0.1875	0.1860	0.2135	0.2105	1.031	0.844	2.844	2.656	4.594	4.406	0.188	0.022
7/32 0.219	0.2187	0.2172	0.2490	0.2460	1.125	0.938	3.094	2.906	4.969	4.781	0.219	0.024
1/4 0.250	0.2500	0.2485	0.2845	0.2815	1.219	1.031	3.344	3.156	5.344	5.156	0.250	0.030
5/16 0.312	0.3125	0.3110	0.3570	0.3531	1.344	1.156	3.844	3.656	6.094	5.906	0.312	0.032
3/8 0.375	0.3750	0.3735	0.4285	0.4238	1.469	1.281	4.344	4.156	6.844	6.656	0.375	0.044
7/16 0.438	0.4375	0.4355	0.5005	0.4944	1.594	1.406	4.844	4.656	7.594	7.406	0.438	0.047
1/2 0.500	0.5000	0.4975	0.5715	0.5650	1.719	1.531	5.344	5.156	8.344	8.156	0.500	0.050
9/16 0.562	0.5625	0.5600	0.6420	0.6356	1.844	1.656	5.844	5.656	9.094	8.906	0.562	0.053
5/8 0.625	0.6250	0.6225	0.7146	0.7080	1.969	1.781	6.344	6.156	9.844	9.656	0.625	0.055
3/4 0.750	0.7500	0.7470	0.8580	0.8512	2.219	2.031	7.344	7.156	11.344	11.156	0.750	0.070
7/8 0.875	0.8750	0.8720	1.0020	0.9931	2.469	2.281	8.344	8.156	12.844	12.656	0.875	0.076
1 1.000	1.0000	0.9970	1.1470	1.1350	2.719	2.531	9.344	9.156	14.344	14.156	1.000	0.081
1-1/4 1.250	1.2500	1.2430	1.440	-	3.250	2.750	11.500	11.000	17.500	17.000	1.250	0.092
1-1/2 1.500	1.5000	1.4930	1.730	-	3.750	3.250	13.500	13.000	20.500	20.000	1.500	0.104
1-3/4 1.750	1.7500	1.7430	2.020	-	4.250	3.750	15.500	15.000	23.500	23.000	1.750	0.115
2 2.000	2.000	1.9930	2.290	-	4.750	4.250	17.500	17.000	26.630	26.130	2.000	0.126

1. Keys and Bits may be chamfered to the limit of K.

Metric Keys & Bits

NOMINAL KEY AND SOCKET SIZE MM	W		Y		B		C				R	L	K
	HEXAGON WIDTH ACROSS FLATS		HEXAGON WIDTH ACROSS CORNERS		LENGTH OF SHORT ARM		LENGTH OF LONG ARM, MM				RADIUS OF BEND MM	LENGTH OF BIT MM	CHAMFER MM
	MM		MM		MM		SHORT SERIES		LONG SERIES				
	MAX.	MIN.	MAX.	MIN.	MAX.	MIN.	MAX.	MIN.	MAX.	MIN.	MIN.	± 1.5	MAX.
0.7	0.711	0.698	0.798	0.762	8	3	34	28	69	63	1.5	-	0.08
0.9	0.889	0.876	0.998	0.960	11	6	34	28	71	65	1.5	-	0.10
1.3	1.270	1.244	1.422	1.372	16	11	44	39	75	69	1.5	-	0.15
1.5	1.500	1.470	1.690	1.640	14	13	45	43	78	76	1.5	-	0.20
2	2.000	1.970	2.250	2.200	16	15	50	48	83	81	2.0	-	0.20
2.5	2.500	2.470	2.820	2.770	18	17	56	53	90	87	2.5	-	0.23
3	3.000	2.960	3.399	3.340	20	18	63	60	100	97	3.0	-	0.38
4	4.000	3.960	4.532	4.470	25	23	70	66	106	102	4.0	-	0.41
5	5.000	4.960	5.690	5.630	28	26	80	76	118	114	5.0	-	0.56
6	6.000	5.950	6.828	6.760	32	30	90	86	140	136	6.0	-	0.76
8	8.000	7.950	9.136	9.030	36	34	100	95	160	155	8.0	-	0.81
10	10.000	9.950	11.470	11.340	40	38	112	106	170	164	10.0	-	1.12
12	12.000	11.950	13.764	13.590	45	43	125	119	212	206	12.0	-	1.27
14	14.000	13.930	16.058	15.880	56	53	140	133	236	229	14.0	-	1.35
17	17.000	16.930	19.499	19.300	63	60	160	152	250	242	17.0	-	1.40
19	19.000	18.930	21.793	21.580	70	67	180	171	280	271	19.0	-	1.78
22	22.000	21.930	25.234	25.000	80	76	200	190	335	325	22.0	-	1.93

CAUTION: Information is for general reference only; for more complete specifications consult the Standards References, or consult Holo-Krome.

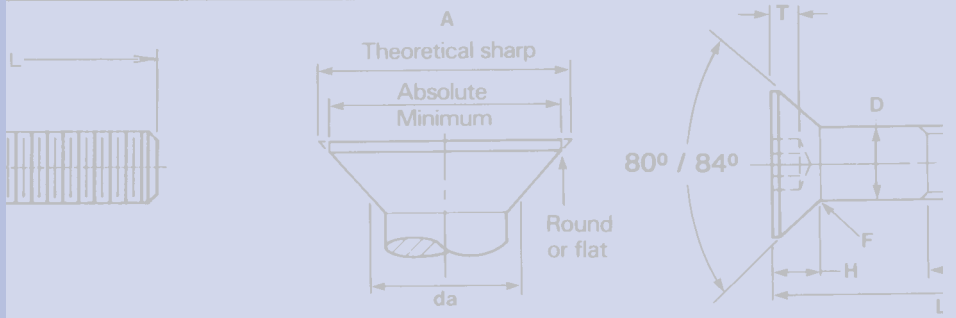
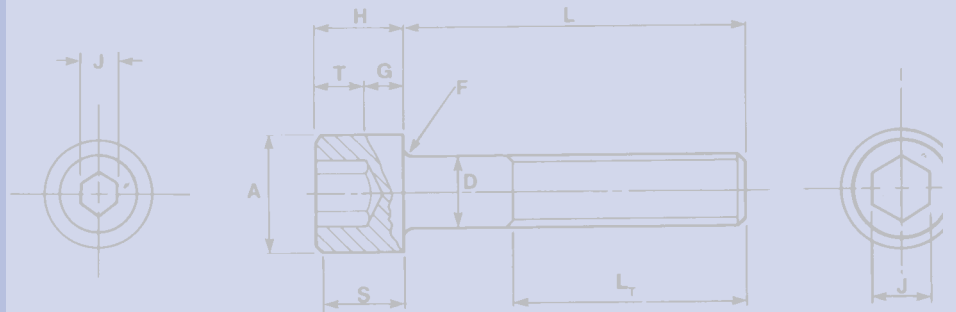

Fastener Technology
... Engineered Solutions

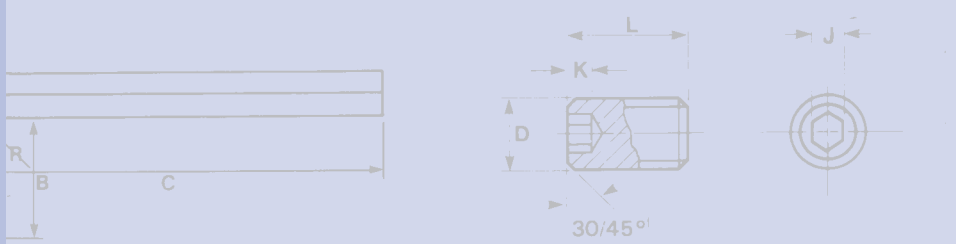
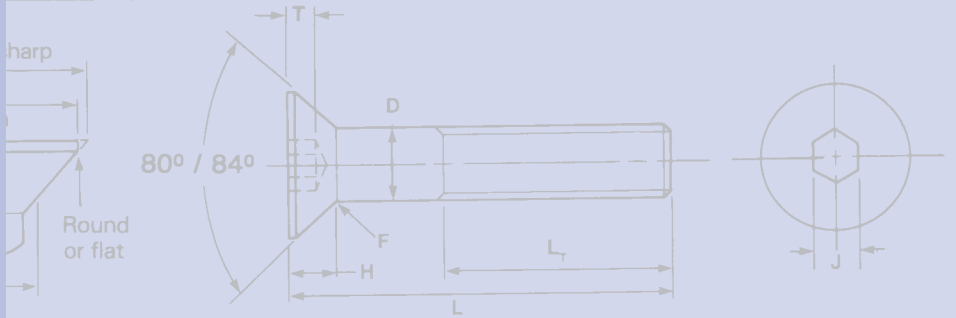
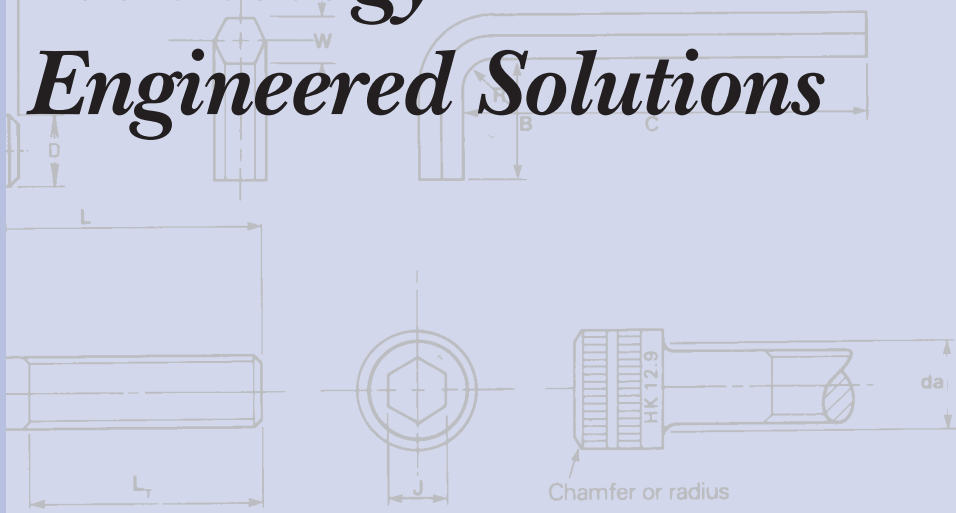

Customer Service

11011 McCormick Road
 Hunt Valley, MD 21031

Toll Free: 800-866-5753
 Fax: 800-234-0472
 Website: www.holokrome.com